

# MLC

## MicroSD Card 3.0

### PHANES-F Series

**Document No. :** 100-xPMSD-PFITMB

**Version No. :** 04V0

**Date :** December, 2022

ISO 9001 : 2015 CERTIFIED



### Product Features

#### ■ Flash IC

- Samsung 14nm NAND Flash IC.
- Multi-Level Cell (MLC) technology

#### ■ Compatibility

- SD Memory Card Specifications, Part 1 Physical Layer Specification, version 3.1 Final
- SD Memory Card Specifications, Part 3, Security Specification, Version 3.0 Final

#### ■ Additional Capabilities

- S.M.A.R.T.\*<sup>1</sup> (Self-Monitoring, Analysis and Reporting Technology) feature set support.
- Supports SD command Class 2/4/6/10
- Supports UHS-1
- Supports SD mode and SPI mode
- Supports CPRM
- Supports Embedded Mode
- Support bad Block Management
- Support both Static and Dynamic Wear Leveling

#### ■ Mechanical

- 8 exposed contact pins on one side.
- Dimension: 15.0mm x 11.0mm x 1.0mm.
- Weight: 0.3 g / 0.01 oz.

#### ■ Power Operating Voltage 3.3V(+/-) 10%

- Read Mode: 400 mA (max.)
- Write Mode: 400 mA (max.)
- Standby Mode: 1000 uA (max.)

#### ■ Performance (Maximum value) \*<sup>2</sup>

##### microSDHC card performance

- Sequential Read: 93.9 MB/sec. (max.)
- Sequential Write: 61.6 MB/sec. (max.)

##### micro SDXC card performance

- Sequential Read: 94.3 MB/sec. (max.)
- Sequential Write: 76.7 MB/sec. (max.)

#### ■ Capacity

- 8GB, 16GB, 32GB and 64GB

#### ■ Reliability

- **ECC:** Designed with BCH ECC Algorithm.
- **MTBF:** > 3,000,000 hours
- **Temperature:** (Operating)  
Wide Temp. Grade: -40°C ~ +85°C
- **Vibration:** 80Hz~2000Hz/20G.
- **Shock:** 0.5ms, 1500 G, 3 axes.
- **Erase counts:** 3K

#### ■ Certifications and Declarations

- **Certifications:** CE & FCC
- **Declarations:** RoHS & REACH

#### Remarks:

- 1. Support official S.M.A.R.T. Utility.
- 2. Sequential performance is based on CrystalDiskMark 5.1.2 with file size 1000MB

### Order Information

#### I. Part Number List

##### ◆ APRO MLC Micro Secure Digital Memory Card PHANES-F Series

Product Picture	Grade	Wide Temp Grade ( -40°C ~ +85°C )
	8GB	WPMSD008G-PFISM
	16GB	WPMSD016G-PFISM
	32GB	WPMSD032G-PFISM

#### II. Part Number Decoder:

**X1 X2 X3 X4 X5 X6 X7 X8 X9** — **X11 X12 X13 X14 X15 X16**

**X1** : Grade

**W**: Wide Temp Grade- operating temp. -40° C ~ +85 ° C

**X12** : Controller version

**A, B, C.....**

**X2** : The material of case

**P** : Plastic casing

**X13** : Controller Grade

**I** : Industrial grade

**X3 X4 X5** : Product category

**MSD** : Micro Secure Digital (SD) memory card

**X14** : Flash IC

**S** : Samsung NAND Flash IC

**X6 X7 X8 X9** : Capacity

**008G:** 8GB      **032G:** 32GB

**016G:** 16GB

**X15** : Flash IC grade / Type

**M** : MLC -NAND Flash IC

**X16** : MLC Technology

**B** : Samsung 14nm MLC

**X11** : Controller

**P** : PHANES Series

### Revision History

Revision	Description	Date
1.0	Initial release	2015/06/12
2.0	Flash IC upgrade to 15nm	2016/03/21
2.1	Add 128GB microSDXC capacity	2017/5/18
2.2	Updated Document form	2019/06/17
2.3	Updated Document form	2020/05/18
3.0	Remove 128GB microSDXC capacity Add. Samsung MLC Flash IC Solution	2021/04/01
3.1	Correct description: Supply Voltage: 3.3V(+/-) 10% to Supply Voltage: 2.7V to 3.6V	2021/07/9
3.2	Add. TBW	2022/04/01
4.0	Remove Kioxia solution	2022/12/22

### Contents

Product Features .....	- 2 -
Order Information .....	- 3 -
<b>I. Part Number List</b> .....	- 3 -
<b>II. Part Number Decoder:</b> .....	- 3 -
Revision History .....	- 4 -
Contents .....	- 5 -
<b>1. Introduction</b> .....	- 6 -
<b>1.1. Scope</b> .....	- 6 -
<b>1.2. Flash Management Technology – Static &amp; Dynamic Wear Leveling</b> .....	- 6 -
<b>1.3. Bad Block Management</b> .....	- 6 -
<b>1.4. Embedded Mode</b> .....	- 6 -
<b>2. Product Specifications</b> .....	- 7 -
<b>2.1. System Environmental Specifications</b> .....	- 7 -
<b>2.2. System Power Requirements</b> .....	- 7 -
<b>2.3. System Performance</b> .....	- 7 -
<b>2.4. System Reliability</b> .....	- 8 -
<b>2.5. Tera Bytes Written</b> .....	- 8 -
<b>2.6. Physical Specifications</b> .....	- 9 -
<b>3. Interface Description</b> .....	- 11 -
<b>3.1. Micro Secure Digital Memory Card interface</b> .....	- 11 -
<b>3.2. Pin Assignments</b> .....	- 11 -
<b>Appendix A: Limited Warranty</b> .....	- 12 -

### 1. Introduction

APRO MLC Micro Secure Digital Memory Card PHANES-F Series is specifically designed to meet the security, performance and environmental requirements of some significant applications such like networking, telecommunications and data-communications, mobile & embedded computing, medical instruments and industrial computing applications.

The main used Flash memory is MLC-NAND Type Flash memory chips are 8GB, 16GB and 32GB. APRO MLC Micro SD Cards include a copyright protection that complies with the security of the SDMI standard, and the physical form-factor, pin assignment.

#### 1.1. Scope

This document describes the key features and specifications of APRO MLC Micro Secure Digital Memory Cards.

#### 1.2. Flash Management Technology – Static & Dynamic Wear Leveling

NAND flash devices can only undergo a limited number of program/erase cycles, and in most cases, the flash media are not used evenly. If some areas get updated more frequently than others, the lifetime of the device would be reduced significantly. Thus, Wear Leveling is applied to extend the lifespan of NAND Flash by evenly distributing write and erase cycles across the media.

APRO MLC Micro Secure Digital Memory Card PHANES-F Series provides advanced Wear Leveling algorithm, which can efficiently spread out the flash usage through the whole flash media area. Moreover, by implementing both dynamic and static Wear Leveling algorithms, the life expectancy of the NAND flash is greatly improved.

#### 1.3. Bad Block Management

##### ➤ Early Bad Block

The fault block generated during the manufacturing process of NAND Flash is called Early Bad Block.

##### ➤ Later Bad Block

In the process of use, as the number of operations of writing and erasing increases, a fault block is gradually generated, which is called a Later Bad Block.

**Bad block management** is a management mechanism for a bad block to be detected by the control IC and mark bad blocks in the NAND Flash and improve the reliability of data access. The bad block management mechanism of the control IC will establish a **Bad Block Table** when the NAND Flash is started for the first time, and will also record the errors found in the process of use in the bad block table, and data is ported to new valid blocks to avoid data loss.

In order to detect the initial bad blocks to handle run time bad blocks, APRO MLC Micro Secure Digital Memory Card PHANES-F Series provides the **Bad Block Management** scheme. It remaps a bad block to one of the reserved blocks so that the data contained in one bad block is not lost and new data writes on a bad block is avoided.

#### 1.4. Embedded Mode

Embedded mode is a function specially designed for operating systems that do not utilize FAT. Often under non Windows OS, for example Linux or customized host, wear leveling mechanism of APRO MLC MicroSD cards will be affected or even disabled in some cases. With embedded mode activated, MLC MicroSD cards ensure that under any circumstances, wear leveling mechanism can operate normally to keep the usage of blocks even throughout the MicroSD card's life cycle. This is especially a great add-on for security cameras or drive recorders.

### 2. Product Specifications

For all the following specifications, values are defined at ambient temperature and nominal supply voltage unless otherwise stated.

#### 2.1. System Environmental Specifications

**Table 1: Environmental Specification**

APRO Micro Secure Digital Memory Card PHANES-F Series		Wide temp Grade
		WPMSDXXXG-PFISM
Temperature	Operating:	-40°C ~ +85°C
	Non-operating:	-50°C ~ +95°C
Humidity	Operating & Non-operating:	10% ~ 95% non-condensing
Vibration	Operating & Non-operating:	80Hz~2000Hz/20G.
Shock	Operating & Non-operating:	0.5ms, 1500 G, 3 axes

#### 2.2. System Power Requirements

**Table 2: Power Requirement**

APRO Micro Secure Digital Memory Card PHANES-F Series		Wide temp Grade
		WPMSDXXXG-PFISM
DC Input Voltage (VCC)		2.7V to 3.6V
Maximum average value	Reading Mode :	400 mA (max.)
	Writing Mode :	400 mA (max.)
	Standby Mode :	1000 uA (max.)

#### 2.3. System Performance

**Table 3: System Performances**

Data Transfer Mode supporting		SDA Specification Ver 3.0			
Capacity level		microSDHC		microSDXC	
Speed level		UHS-1 (Grade-1)	UHS-1 (Grade-3)		UHS-1 (Grade-3)
Flash	Capacity	8GB	16GB	32GB	64GB
Samsung	Sequential Read (MB/s)	90.0	90.0	90.0	n/a
	Sequential Write (MB/s)	30.0	60.0	60.0	n/a

Note:

- All values quoted are typically at 25°C and nominal supply voltage.
- The performance is obtained from TestMetrix Test (@500MB).

### 2.4. System Reliability

**Table 4: System Reliability**

<b>Wear-leveling Algorithms</b>	Static and Dynamic wear-leveling algorithms
<b>Bad Blocks Management</b>	Supportive
<b>ECC Technology</b>	BCH ECC
<b>MTBF</b>	> 3,000,000 hours
<b>Endurance</b>	NAND MLC Flash w/MLC Technology : 3K Erase counts
<b>Durability</b>	10,000 inserting cycles
<b>Bending</b>	>10N
<b>Torque</b>	0.1N +/- 2.5 deg.
<b>Drop Test</b>	1.5M free fall
<b>Salt Spray</b>	Concentration: 3% NaCl/35°C
<b>Waterproof</b>	1000mm submerge for 30 minutes, IPx7 compliance
<b>Electrostatic Discharge (ESD)</b>	Contact: +/- 4KV each item 5 times Air: +/- 8KV 5 times
<b>X-Ray Exposure Test</b>	0.1 Gy of medium energy radiation (70 keV to 140keV, cumulative does per year) to both sides of the card.

Note:

- The endurance of SSD could be estimated based on user behavior, NAND endurance cycles, and write amplification factor. It is not guaranteed by flash vendor.

### 2.5. Tera Bytes Written

**Table 4: System Reliability**

<b>Erase counts</b>	NAND MLC Flash Cell Level : 3K P/E Cycles
<b>Capacity</b>	<b>TBW(TB)</b>
<b>8GB</b>	23
<b>16GB</b>	47
<b>32GB</b>	93

- Workload by Sequential Write.

The endurance of SSD could be varying based on user behavior, NAND endurance cycles, and write amplification factor. It is not guaranteed by flash vendor.



### 2.6. Physical Specifications

Refer to Table 5 and see Figure 1 for APRO MLC Micro Secure Digital Memory Card PHANES-F Series physical specifications and dimensions.

**Table 5: Physical Specifications of APRO MLC Micro Secure Digital Memory Card PHANES-F Series**

<b>Length:</b>	15.00 mm
<b>Width:</b>	11.00 mm
<b>Thickness:</b>	1.0 mm
<b>Weight:</b>	0.3 g / 0.01 oz

**Figure 2: APRO MLC Micro Secure Digital Memory Card PHANES-F Series Dimension**

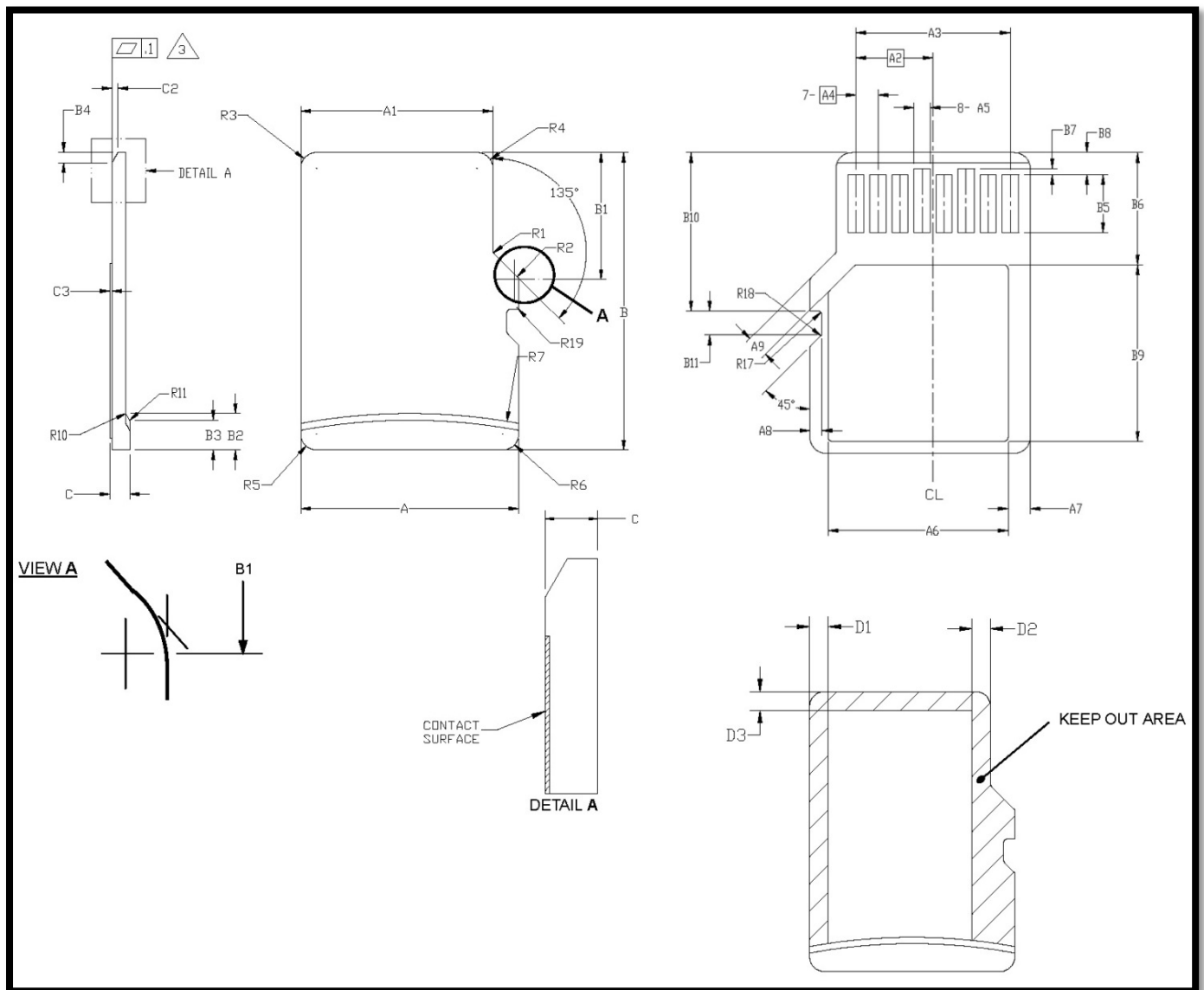

SYMBOL	COMMON DIMENSIONS			NOTE
	MIN	NOM	MAX	
A	10.90	11.00	11.10	
A1	9.60	9.70	9.80	
A2	-	3.85	-	BASIC
A3	7.60	7.70	7.80	
A4	-	1.10	-	BASIC
A5	0.75	0.80	0.85	
A6	-	-	8.50	
A7	0.90	-	-	
A8	0.60	0.70	0.80	
A9	0.80	-	-	
B	14.90	15.00	15.10	
B1	6.30	6.40	6.50	
B2	1.64	1.84	2.04	
B3	1.30	1.50	1.70	
B4	0.42	0.52	0.62	
B5	2.80	2.90	3.00	
B6	5.50	-	-	
B7	0.20	0.30	0.40	
B8	1.00	1.10	1.20	
B9	-	-	9.00	
B10	7.80	7.90	8.00	
B11	1.10	1.20	1.30	
C	0.90	1.00	1.10	
C1	0.60	0.70	0.80	
C2	0.20	0.30	0.40	
C3	0.00	-	0.15	
D1	1.00	-	-	
D2	1.00	-	-	
D3	1.00	-	-	
R1	0.20	0.40	0.60	
R2	0.20	0.40	0.60	
R3	0.70	0.80	0.90	
R4	0.70	0.80	0.90	
R5	0.70	0.80	0.90	
R6	0.70	0.80	0.90	
R7	29.50	30.00	30.50	
R10	-	0.20	-	
R11	-	0.20	-	
R17	0.10	0.20	0.30	
R18	0.20	0.40	0.60	
R19	0.05	-	0.20	

Notes:

1. DIMENSIONING AND TOLERANCING PER ASME Y14.5M-1994.

2. DIMENSIONS ARE IN MILLIMETERS.

3.  COPLANARITY IS ADDITIVE TO C1 MAX THICKNESS.

### 3. Interface Description

#### 3.1. Micro Secure Digital Memory Card interface

APRO MLC Micro Secure Digital Memory Card has 8 exposed contacts on one side.

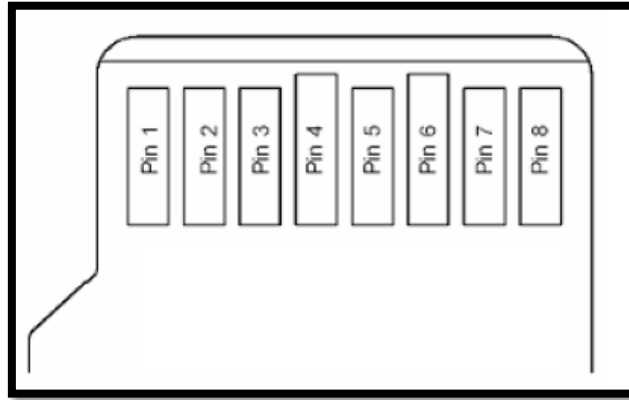

Figure 3: 8 Pins Connector

#### 3.2. Pin Assignments

There are total of 8 pins in the Micro SD Connector. The pin assignments are listed in below table 6.

Table 6 - Pin Assignments

Pin Number	SD Mode			SPI Mode		
	Pin Name	Type <sup>1</sup>	Description	Pin Name	Type	Description
Pin 1	DAT2	I/O/PP	Data Line [bit2]	RSV		
Pin 2	CD / DAT3 <sup>2</sup>	I/O/PP <sup>3</sup>	Card Detect / Data Line [bit3]	CS	I <sup>3</sup>	Chip Select
Pin 3	CMD	PP	Command / Response	DI	I	Data in
Pin 4	V <sub>DD</sub>	S	Supply voltage	V <sub>DD</sub>	S	Supply voltage
Pin 5	CLK	I	Clock	SCLK	I	Clock
Pin 6	V <sub>SS</sub>	S	Supply voltage ground	V <sub>SS</sub>	S	Supply voltage ground
Pin 7	DAT0	I/O/PP	Data Line [bit0]	DO	O/PP	Data Out
Pin 8	DAT1	I/O/PP	Data Line [bit1]	RSV		

- S: power supply, I:input; O:output using push-pull drivers; PP:I/O using push-pull drivers.
- The extended DAT lines (DAT1-DAT3) are input on power up. They start to operate as DAT lines after SET\_BUS\_WIDTH command. The Host shall keep its own DAT1-DAT3 lines in input mode, as well, while they are not used. It is defined so, in order to keep compatibility to Multi-Media Cards.
- At power up this line has a 50KOhm pull up enabled in the card. This resistor serves two functions Card detection and Mode Selection. For Mode Selection, the host can drive the line high or let it be pulled high to select SD mode. If the host wants to select SPI mode it should drive the line low. For Card detection, the host detects that the line is pulled high. This pull-up should be disconnected by the user during regular data transfer period, with SET\_CLR\_CARD\_DETECT(ACMD42) command.

### **Appendix A: Limited Warranty**

APRO warrants your MLC Micro Secure Digital Memory Card PHANES-F Series against defects in material and workmanship for the life of the drive. The warranty is void in the case of misuse, accident, alteration, improper installation, misapplication or the result of unauthorized service or repair. The implied warranties of merchantability and fitness for a particular purpose, and all other warranties, expressed or implied, except as set forth in this warranty, shall not apply to the products delivered. In no event shall APRO be liable for any lost profits, lost savings or other incidental or consequential damages arising out of the use of, or inability to use, this product.

**BEFORE RETURNING PRODUCT, A RETURN MATERIAL AUTHORIZATION (RMA) MUST BE OBTAINED FROM APRO.**

Product shall be returned to APRO with shipping prepaid. If the product fails to conform based on customers' purchasing orders, APRO will reimburse customers for the transportation charges incurred.

#### **WARRANTY PERIOD:**

- **MLC ( Standard grade / Wide temp. grade )    2 years / Within 3K Erasing Counts**

This document is for information use only and is **subject to change without prior notice**. APRO Co., Ltd. assumes no responsibility for any errors that may appear in this document, nor for incidental or consequential damages resulting from the furnishing, performance or use of this material. No part of this document may be reproduced, transmitted, transcribed, stored in a retrievable manner or translated into any language or computer language, in any form or by any means, electronic, mechanical, magnetic, optical, chemical, manual or otherwise, without the prior written consent of an officer of APRO Co., Ltd.

All parts of the APRO documentation are protected by copyright law and all rights are reserved.

APRO and the APRO logo are registered trademarks of APRO Co., Ltd.

Product names mentioned herein are for identification purposes only and may be trademarks and/or registered trademarks of their respective companies.

© 2022 APRO Corporation. All rights reserved