

S101M9L

10.1" ARM A73 + A53 Rugged Android Tablet



KEY FEATURES

- 10.1" 1280 x 800 TFT LCD Display, rugged android tablet
- 8.0 MP Camera in Front Side
- 13.0 MP Rear Camera (with LED auxiliary light, Auto Focus)
- 4 GB RAM + 32 GB eMMC
- Android™ 11.0
- Integrated 1D/2D Barcode Reader (Optional)
- Integrated NFC Module (Optional)



SPECIFICATIONS

Display			
Bonding	Optical Bonding for Sunlight Viewability	Type	Projected Capacitive Multi Touch
Viewability	Anti-Glare touch treatment	Touch Mode	Support Hand / Gloves and Rain Mode
Resolution	1280x800	Size	10.1 inches
Contrast Ratio	1000:1	Panel Brightness	400.0 nits
View Angles	80,80,80,80		
System Specification			
Processor	ARM A73 x 4 (2.0 GHz) + A53 x 4 (2.0 GHz)	Memory	4GB
Storage	32GB	Operating System	Android 11.0
WLAN	Support	BT	Support
WWAN	4G/LTE (Optional)	GNSS	GPS/GLONASS
RFID	NFC (Read / Write, Peer to Peer mode) (Optional)	Sensors	Ambient Light Sensor, E-Compass, Gyro, Acceleration Sensors
Camera			
Front Camera	8MP Camera	Rear Camera	13MP Camera with LED Auxiliary Light (Auto Focus)
Mechanical			
Dimension	268 x 187 x 22.2 mm	Weight	1.0 kg
IO Ports			
USB Port	1 x USB Type C OTG 1 x USB Type A	SD Card Slot	1 x Micro SD Card Slot
SIM Card Slot	1 x SIM Card Slot	Video	1 x Micro HDMI (Optional)
Audio	1 x Audio Combo connector (Mic in or Line Out) 1 x Speaker	LAN	1 x RJ45
Indicator	2 x LED Indicators (Power, Battery)	Docking Connector	1 x Docking Connector
Environment			
Operating Humidity	10% to 90% RH, Non-Condensing	Operating Temperature	-20°C to 60°C
Storage Temperature	-30°C to 70°C	Shock	MIL-STD-810H Method 516.8 Procedure I
Vibration	MIL-STD-810H Method 514.8 Procedure I	IP rating	IP65
Drop	MIL-STD-810H Method 516.8, 4 ft		

Certification			
Certification	CE, FCC		
Control			
Button	1 x Power Button, 2 x Function button		
Power			
Battery	11.4V, typ. 3500 mAh Li-Ion Battery(39.9W), Support Warm Swap function (Optional)	Battery Operating Time	10Hr
Power Rating	19V	Adapter	19V 3.42A Adapter
Security Function			
SOTI MobiControl	SOTI MobiControl Compliance	Kensington Lock	Kensington Lock
Barcode Scanner			
Barcode Scanner	1D/2D Barcode Reader (Optional)		
Accessory			
Accessory	Adapter and Power Cord Standard Battery	Optional Accessory	Hand Strap Shoulder Strap Battery Charger Capacitive Stylus Vehicle Charger Vehicle Docking Carry Bag Desk Dock Micro SD Card HDMI Adapter

DIMENSIONS UNIT:MM

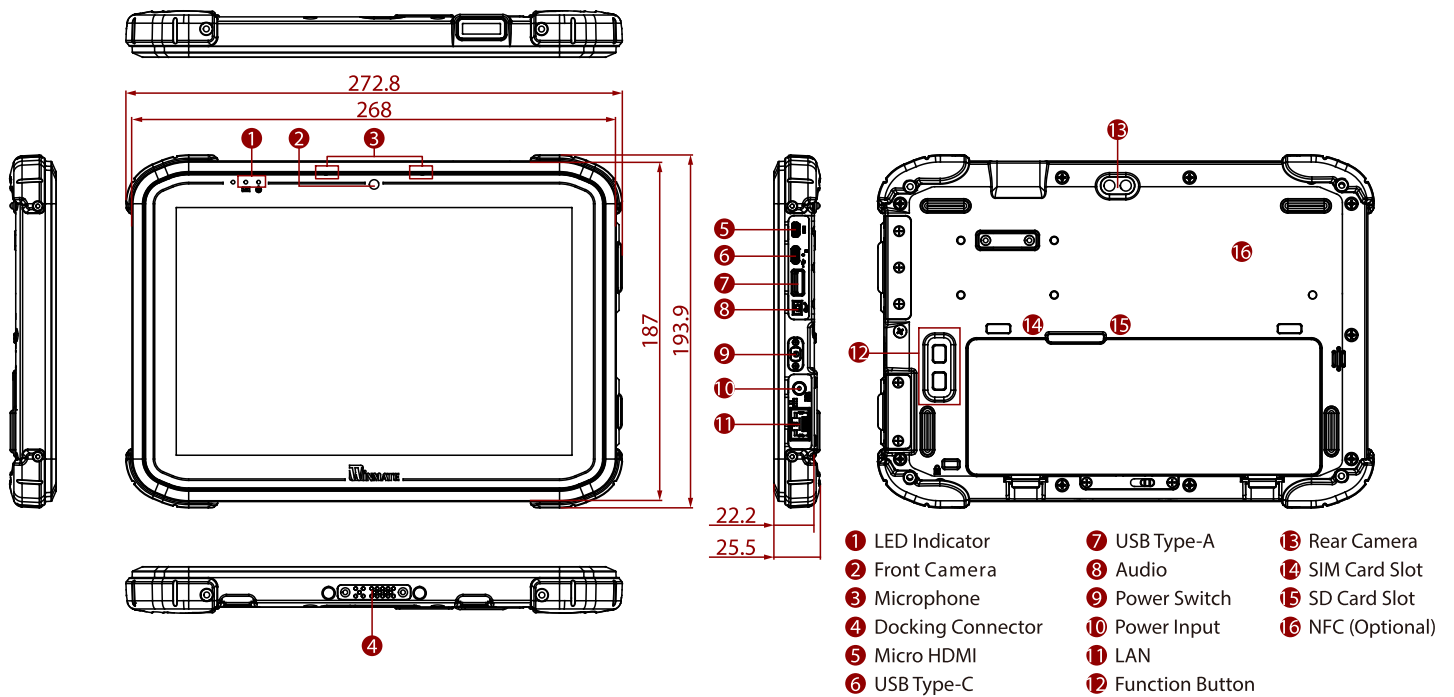

NOTE

1. This is a simplified drawing and some components are not marked in detail.
2. Please contact our sales representative if you need further product information.
3. All specifications are subject to change without prior notice.
4. The product shown in this datasheet is a standard model. For diagrams that contain customized or optional I/O, please contact the Winmate Sales Team for more information.
5. Total usable memory will be less depending upon actual system configuration.
6. Length measurements do not include protrusions. Weight varies with optional functions.
7. Measured at dimming LCD brightness. Varies depending on the usage conditions, or when an external device is attached.
8. Accessories and Integrated Options may vary depending on your configuration.
9. Battery operating time will be varied by using scenarios.