

SLC

Industrial SD/SDHC Card 2.0

THEMIS-A Series

Document No. : 100-xPSDC-EATS

Version No. : 02V1

Date : August, 2023

ISO 9001 : 2015 CERTIFIED



Product Features

■ Flash IC

- TOSHIBA NAND Flash IC.
- Single-Level Cell (SLC) management

■ Compatibility

- Fully compatible to SDA Specifications V1.01/V1.1/V2.0

■ Additional Capabilities

- Supports SD command Class 2,4,5, 6,7,8,10
- Supports SD mode and SPI mode
- Supports CPRM
- Support bad Block Management
- Support both Global Wear Leveling

■ Mechanical

- 9 exposed contact pins on one side.
- Dimension: 32.0mm x 24.0mm x 2.1mm.
- Weight: 2.5 g / 0.09 oz.

■ Power Operating Voltage 3.3V(+/-) 5%

- Read Mode: 49.8 mA (max.)
- Write Mode: 52.2 mA (max.)
- Idle Mode: 0.2 mA (max.)

■ Performance (Maximum value) *2

- SD card performance

- Sequential Read: 22.1 MB/sec. (max.)
- Sequential Write: 16.8 MB/sec. (max.)

- SDHC card performance

- Sequential Read: 22.3 MB/sec. (max.)
- Sequential Write: 18.7 MB/sec. (max.)

■ Capacity

- SD card: 128MB, 256MB, 512MB, 1GB, 2GB
- SDHC card: 4GB, 8GB, 16GB and 32GB.

■ Reliability

- **TBW:** Up to 1,041.67 TBW at 32GB Capacity. (workload by Sequential Write)
- **ECC:** Up to 16bits per 1024bytes in an ECC block.
- **MTBF:** > 3,000,000 hours
- **Temperature:** (Operating)
Standard Grade: 0°C ~ +70°C
Industrial Grade: -40°C ~ +85°C
- **Vibration:** 70Hz~2K Hz / 20G.
- **Shock:** 0.5ms, 1500G, 3 axes
- **Erase counts:** 60K

■ Certifications and Declarations

- **Certifications:** CE & FCC
- **Declarations:** RoHS & REACH

Remarks:

1. Support official S.M.A.R.T. Utility.
2. Sequential performance is based on CrystalDiskMark

Order Information

I. Part Number List

◆ APRO SLC Industrial Secure Digital Memory Card THEMIS-A Series

Product Picture	Grade	Industrial Grade (-40°C ~ +85°C)
	128MB	WPSDC128M-EAITI
	256MB	WPSDC256M-EAITI
	512MB	WPSDC512M-EAITI
	1GB	WPSDC001G-EAITI
	2GB	WPSDC002G-EAITI
	4GB	WPSDH004G-EAITI
	8GB	WPSDH008G-EAITI
	16GB	WPSDH016G-EAITI
	32GB	WPSDH032G-EAITI

II. Part Number Decoder:

X1 X2 X3 X4 X5 X6 X7 X8 X9 — **X11 X12 X13 X14 X15**

X1 : Grade

W: Industrial Grade- operating temp. -40° C ~ +85 ° C

X12 : Controller version

A, B, C.....

X2 : The material of case

P : Plastic casing

X13 : Controller Grade

I : Industrial grade

X3 X4 X5 : Product category

SD : Secure Digital (SD) memory card

SDH : Secure Digital High Capacity (SDHC)

memory card

X14 : Flash IC

T : Toshiba NAND Flash IC

X15 : Flash IC grade / Type

I : Industrial grade

X6 X7 X8 X9 : Capacity

128M:	128MB	004G	4GB
256M	256MB	008G:	8GB
512M:	512MB	016G	16GB
001G	1GB	032G	32GB
002G	2GB		

X11 : Controller

E : THEMIS Series

Revision History

Revision	Description	Date
1.0	Initial release	2015/10/14
1.1	Typo correction	2019/3/29
2.0	Updated Document form	2019/06/17
2.1	Add TBW	2023/08/01

Contents

Product Features	- 2 -
Order Information	- 3 -
I. Part Number List	- 3 -
II. Part Number Decoder:	- 3 -
Revision History	- 4 -
Contents	- 5 -
1. Introduction	- 6 -
1.1. Scope	- 6 -
1.2. Flash Management Technology – Global Wear Leveling	- 6 -
1.3. Bad Block Management	- 6 -
1.4. Mean Time Between Failure (MTBF)	- 7 -
1.4.1. Definition	- 7 -
1.4.2. Obtaining MTBF	- 7 -
1.4.3. Definitions	- 8 -
2. Product Specifications	- 9 -
2.1. System Environmental Specifications	- 9 -
2.2. System Power Requirements	- 9 -
2.3. System Performance	- 10 -
2.4. System Reliability	- 10 -
2.5. Physical Specifications	- 12 -
3. Interface Description	- 13 -
3.1. Secure Digital Memory Card interface	- 13 -
3.2. Pin Assignments	- 14 -
Appendix A: Limited Warranty	- 15 -

1. Introduction

APRO SLC Industrial Secure Digital Memory Card THEMIS-A Series is specifically designed to meet the security, performance and environmental requirements of some significant applications such like networking, telecommunications and data-communications, mobile & embedded computing, medical instruments and industrial computing applications.

The main used Flash memory is SLC-NAND Type Flash memory chips are 128MB, 256MB, 512MB, 1GB, 2GB, 4GB, 8GB, 16GB and 32GB. APRO SLC Industrial Secure Digital Memory Card THEMIS-A Series include a copyright protection that complies with the security of the SDMI standard, and the physical form-factor, pin assignment.

1.1. Scope

This document describes the key features and specifications of APRO SLC Industrial Secure Digital Memory Card THEMIS-A Series.

1.2. Flash Management Technology – Global Wear Leveling

In order to gain the best management for flash memory, APRO SLC Industrial Secure Digital Memory Card THEMIS-A Series supports Global Wear-leveling technology to manage the Flash system. The life of flash memory is limited; the management is to increase the life of the flash product.

Wear-leveling algorithm evenly distributes data over an entire Flash cell array and searches for the least used physical blocks. The identified low cycled sectors are used to write the data to those locations. If blocks are empty, the write occurs normally. If blocks contain data, it moves that data to a more heavily used location before it moves the newly written data. Wear leveling maximizes effective endurance Flash array compared to no wear leveling products.

1.3. Bad Block Management

➤ **Early Bad Block**

The fault block generated during the manufacturing process of NAND Flash is called Early Bad Block.

➤ **Later Bad Block**

In the process of use, as the number of operations of writing and erasing increases, a fault block is gradually generated, which is called a Later Bad Block.

Bad block management is a management mechanism for a bad block to be detected by the control IC and mark bad blocks in the NAND Flash and improve the reliability of data access. The bad block management mechanism of the control IC will establish a **Bad Block Table** when the NAND Flash is started for the first time, and will also record the errors found in the process of use in the bad block table, and data is ported to new valid blocks to avoid data loss.

In order to detect the initial bad blocks to handle run time bad blocks, APRO SLC Industrial Secure Digital Memory Card THEMIS-A Series provides the **Bad Block Management** scheme. It remaps a bad block to one of the reserved blocks so that the data contained in one bad block is not lost and new data writes on a bad block is avoided.

1.4. Mean Time Between Failure (MTBF)

1.4.1. Definition

MTBF (Mean time between failures) is defined as failure or maintenance required for the average time including failure detection and maintenance for the device. For a simple and maintainable unit, $MTBF = MTTF + MTTR$.

MTTF (mean time to failure) is defined as the expectation of random variables for time to failure.

MTTR (mean time to restoration) is the expectation of random variables of time required for restoration which includes the time required for confirmation that a failure occurred, as well as the time required for maintenance.

1.4.2. Obtaining MTBF

There are two methods for obtaining MTBF:

A. MTBF software estimation method: by calculating all the MTBF data of all the components included in the bill of material, and the data of the completed products including actual parameters of voltage and electrical current using analysis software, the MTBF of the completed product is estimated.

B. MTBF sample test method: by determining a certain number of samples and a fixed time for testing, using a Arrhenius Model and Coffin-Manson Model to obtain parameters, and then using the formula with the parameters, the longevity and in so the reliability is proved.

Arrhenius Model: $Af = e\{ (1/k \times Ea (1/273+Tmax - 1/273+Ttest))\}$

Coffin-Manson Model: $Af = (\Delta Ttest/\Delta Tuse)m$

➤ **APRO uses the A method to Estimate MTBF**

MTBF is actually obtained by calculation which is just an estimation of future occurrences. The main reason to use the first method is that the data contains the analysis by all the parameters of components and actual parameters of voltage and electrical current of finished products, which is considered adequate and objective.

➤ **Interpretation of MTBF Analysis**

APRO estimates MTBF using a prediction methodology based on reliability data for the individual components in APRO products. The predicted MTBF based on Parts stress analysis Method of Telcordia Special Report SR-332, for components failure rates. Component data comes from several sources: device life tests, failure analysis of earlier equipment, device physics, and field returns.

The Telcordia model is based on the Telcordia document, Reliability Prediction Procedure for Electronic Equipment, Technical Reference SR-332. This standard basically modified the component models in MIL-HDBK-217 to better reflect the failure rates that AT&T Bell Lab equipment was experiencing in the field and was originally developed by AT&T Bell Lab as the Bellcore model.

This model supports different failure rate calculation methods in order to support the taking into account of stress, burn-in, laboratory, or field data. A Parts Count or Parts Stress analysis is included in Telcordia performance. Relex supports Telcordia Issues 1 and 2 and also Bellcore Issues 4, 5, and 6. Telcordia Issue 2, released in September 2006, are supported by Relex and Telcordia Issue 1, released in May 2001, is replaced with Relex. Refer to Telcordia Issue 2 Fields for information about the fields in Relex Reliability Studio specific to Telcordia Issue 2.

➤ Purpose of the analyses

The purpose of these analyses is to obtain early estimation of device reliability during engineering and customer validation stages. The prediction results will expose the reliability of whole assembly, viewed as a set of serially connected electronic components. Rating of the assembly electronic components will show the ratio between actual critical elements parameters and their specification limits. The purpose of component rating is to improve a product's inherent design reliability, increase its number of operating times, and to reduce warranty costs and to achieve a more robust design.

1.4.3. Definitions

Term	Definition
Failure	The event, or inoperable state, in which any item or part of an item does not, or would not, perform as previously specified.
Failure rate	The total number of failures within an item population, divided by the total number of life units expended by that population, during a particular measurement interval under stated condition.
FIT	Failures In Time: the number of failures in 1 billion hours.
PPM	Part per million: the number of failures in 1 million hours.
Mean Time Between Failures (MTBF)	A basic measure of reliability for repairable items: The mean number of life units during which all parts of the item perform within their specified limits, during a particular measurement interval under stated conditions..
GB	Ground, Fixed, Controlled: Nearly zero environmental stress with optimum engineering operation and maintenance. Typical applications are central office, environmentally controlled vaults, environmentally controlled remote shelters, and environmentally controlled customer premise area.
GF	Ground, Fixed, Uncontrolled: Some environmental stress with limited maintenance. Typical applications are manholes, poles, remote terminals, and customer premise areas subject to shock, vibration, temperature, or atmospheric variations.

➤ Software & Database

Analysis Software & Analysis Method

Software Name : Relex Reliability Studio 2008

Software Version : Relex Studio 2008

Analysis Method

The prediction method used was Telcordia SR-332, Issue 2,

Parts Count

Failure rate (λ) = 10^9 hours (FITs)

MTBF=1/ λ

$\lambda_{SSi} = \lambda_{Gi} \cdot TT_{Qi} \cdot TT_{Si} \cdot TT_{Ti}$

Where λ_{Gi} Generic steady-state failure rate for device i

TT_{Qi} Quality factor for device i

TT_{Si} Stress factor for device i

TT_{Ti} Temperature factor for device i

➤ **Calculation Parameter**

- Operation Temperature : 25°C
- Environment : Ground Benign, Controlled
- Operation Stress : 50% (Voltage, Current, Power)
- Method : Method I, Case 3

Products are advertised with MTBF up to 1 million hours in the market. Take one million hours as an example, the product's estimated life is 114 years. However, the current rapid progress of technology, advancement of flash storage device's manufacturing process research and development, and the supply period of former flash IC manufacturing processes are crucial to the actual life expectancy of flash products. In short, the MTBF of flash storage is for reference only. Good customer service and technical support provided by manufacturers is the most significant issue regarding to the life-span of products.

Remark:

All the details of testing and data are for reference only and do not imply any products performance as a result. MTBF is only an estimated date and is depends on both hardware and software. User shall not assume that all the products have the same MTBF as APRO estimates.

2. Product Specifications

For all the following specifications, values are defined at ambient temperature and nominal supply voltage unless otherwise stated.

2.1. System Environmental Specifications

Table 1: Environmental Specification

APRO SLC Industrial Secure Digital Memory Card THEMIS-A Series		Environmental Specification
Temperature	Operating:	-40°C ~ +85°C
	Non-operating:	-50°C ~ +95°C
Humidity	Operating & Non-operating:	10% ~ 95% non-condensing
Vibration	Operating & Non-operating:	70Hz~2K Hz/20G.
Shock	Operating & Non-operating:	0.5ms, 1500 G, 3 axes

2.2. System Power Requirements

Table 2: Power Requirement

APRO SLC Industrial Secure Digital Memory Card THEMIS-A Series		DC Input Voltage (VCC): 3.3V(+/-) 5%
Maximum average value	Reading Mode :	49.8 mA (max.)
	Writing Mode :	52.2 mA (max.)
	Idle Mode :	0.2 mA (max.)

2.3. System Performance

Table 3: System Performances

Data Transfer Mode supporting		SDA Specification Ver 3.0								
Average Access Time		1 ms (estimated)								
Maximum Performance	Capacity	128MB	256MB	512MB	1GB	2GB	4GB	8GB	16GB	32GB
	Sequential Read (MB/s)	21.3	21.6	22.0	22.0	22.1	22.2	22.3	22.2	22.2
	Sequential Write (MB/s)	5.3	11.9	13.4	11.9	16.8	18.3	18.7	17.8	18.7

Note:

- All values quoted are typically at 25°C and nominal supply voltage.
- Base on CrystalDiskMark 3.01 with file size 1000MB Test

2.4. System Reliability

Table 4: System Reliability

Wear-leveling Algorithms	Global wear-leveling algorithms
Bad Blocks Management	Supportive
ECC Technology	Up to 16bits per 1024bytes in an ECC block
Endurance	NAND SLC Flash : 60K Erase counts
Durability	10,000 inserting cycles
Bending	>10N
Torque	0.1N +/- 2.5 deg.
Drop Test	1.5M free fall
Salt Spray	Concentration: 3% NaCl/35°C
Waterproof	1000mm submerge for 30 minutes, IPx7 compliance
Electrostatic Discharge (ESD)	Contact: +/- 4KV each item 25 times Air: +/- 8KV 10 times
X-Ray Exposure Test	0.1 Gy of medium energy radiation (70 keV to 140keV, cumulative does per year) to both sides of the card.

Note:

- The endurance of SSD could be estimated based on user behavior, NAND endurance cycles, and write amplification factor.
It is not guaranteed by flash vendor.

Table 5: Tera Bytes Written

Wear-leveling Algorithms	Global wear-leveling algorithms	
Bad Block Management	Supportive	
ECC Technology	Up to 16bits per 1024bytes in an ECC block.	
Erase counts	SLC NAND Flash: 60K P/E Cycles	
TBW (Tera Bytes Written)	Sequential workload	
Capacity	128MB	4.07
	256MB	8.14
	512MB	16.28
	1GB	32.55
	2GB	65.10
	4GB	130.21
	8GB	260.42
	16GB	520.83
	32GB	1,041.67

Note:

Sequential: Mainly sequential write.

2.5. Physical Specifications

Refer to Table 5 and see Figure 1 for APRO SLC Secure Digital Memory Card THEMIS-A Series physical specifications and dimensions.

Table 6: Physical Specifications of APRO SLC Secure Digital Memory Card THEMIS-A Series

Length:	32.00 mm
Width:	24.00 mm
Thickness:	2.10 mm
Weight:	2.5 g / 0.09 oz

Figure 1: APRO SLC Secure Digital Memory Card THEMIS-A Series Dimension

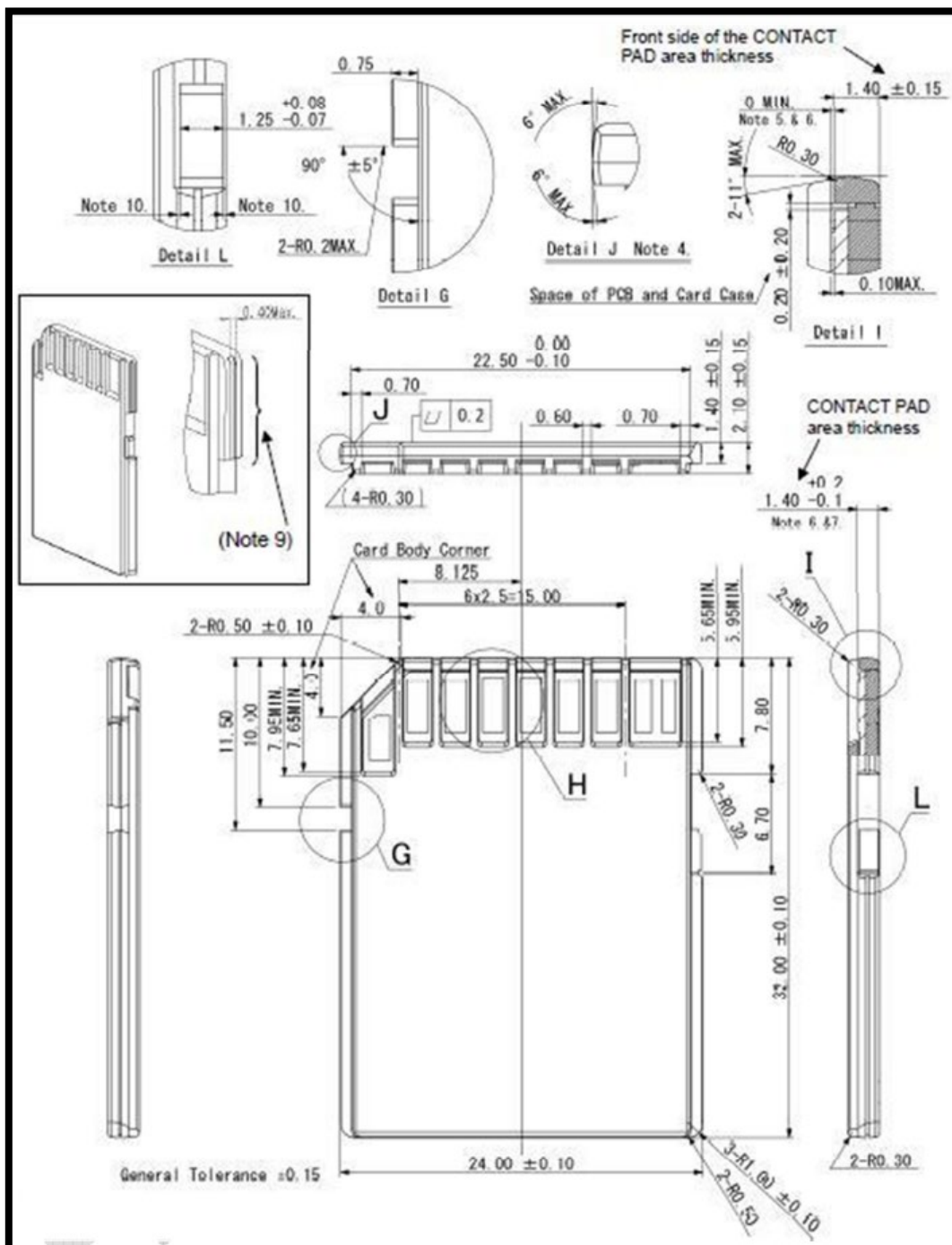

3. Interface Description

3.1. Secure Digital Memory Card interface

APRO SLC Secure Digital Memory Card has 9 exposed contacts on one side.

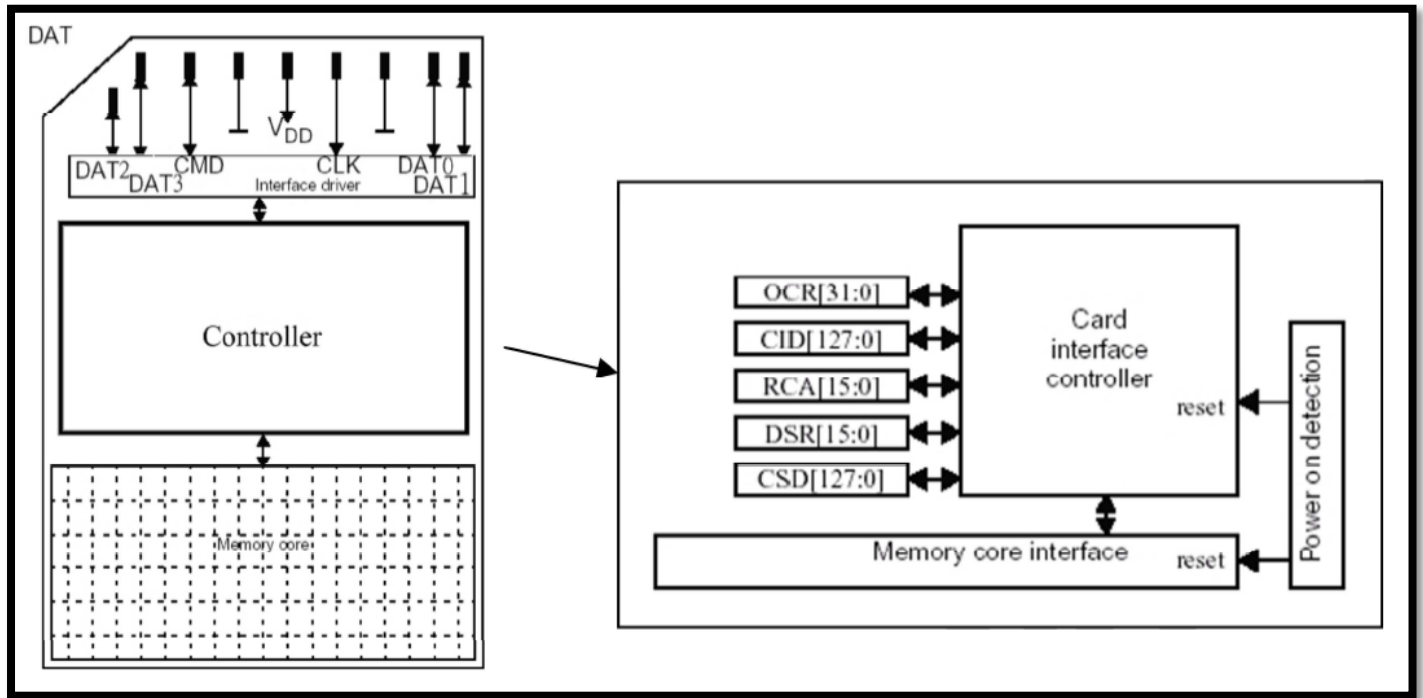

Figure 2: 9 Pins Connector

3.2. Pin Assignments

There are total of 9 pins in the Micro SD Connector. The pin assignments are listed in below table 7.

Table 7 - Pin Assignments

Pin Number	SD Mode			SPI Mode		
	Pin Name	Type ¹	Description	Pin Name	Type	Description
Pin 1	CD / DAT3 ²	I/O/PP ³	Card Detect / Data Line [bit3]	CS	I ³	Chip Select
Pin 2	CMD	PP	Command / Response	DI	I	Data in
Pin 3	V _{SS1}	S	Supply voltage ground	V _{SS}	S	Supply voltage ground
Pin 4	V _{DD}	S	Supply voltage	V _{DD}	S	Supply voltage
Pin 5	CLK	I	Clock	SCLK	I	Clock
Pin 6	V _{SS2}	S	Supply voltage ground	V _{SS2}	S	Supply voltage ground
Pin 7	DAT0	I/O/PP	Data Line [bit0]	DO	O/PP	Data Out
Pin 8	DAT1	I/O/PP	Data Line [bit1]	RSV		
Pin 9	DAT2	I/O/PP	Data Line [bit2]	RSV		

- S: power supply, I:input; O:output using push-pull drivers; PP:I/O using push-pull drivers.
- The extended DAT lines (DAT1-DAT3) are input on power up. They start to operate as DAT lines after SET_BUS_WIDTH command. The Host shall keep its own DAT1-DAT3 lines in input mode, as well, while they are not used. It is defined so, in order to keep compatibility to Multi-Media Cards.
- At power up this line has a 50KOhm pull up enabled in the card. This resistor serves two functions Card detection and Mode Selection. For Mode Selection, the host can drive the line high or let it be pulled high to select SD mode. If the host wants to select SPI mode it should drive the line low. For Card detection, the host detects that the line is pulled high. This pull-up should be disconnected by the user during regular data transfer period, with SET_CLR_CARD_DETECT(ACMD42) command.

Appendix A: Limited Warranty

APRO warrants your SLC Secure Digital Memory Card THEMIS-A Series against defects in material and workmanship for the life of the drive. The warranty is void in the case of misuse, accident, alteration, improper installation, misapplication or the result of unauthorized service or repair. The implied warranties of merchantability and fitness for a particular purpose, and all other warranties, expressed or implied, except as set forth in this warranty, shall not apply to the products delivered. In no event shall APRO be liable for any lost profits, lost savings or other incidental or consequential damages arising out of the use of, or inability to use, this product.

BEFORE RETURNING PRODUCT, A RETURN MATERIAL AUTHORIZATION (RMA) MUST BE OBTAINED FROM APRO.

Product shall be returned to APRO with shipping prepaid. If the product fails to conform based on customers' purchasing orders, APRO will reimburse customers for the transportation charges incurred.

WARRANTY PERIOD:

- **SLC IND. Grade 5 years / Within 60K Erasing Counts**

This document is for information use only and is **subject to change without prior notice**. APRO Co., Ltd. assumes no responsibility for any errors that may appear in this document, nor for incidental or consequential damages resulting from the furnishing, performance or use of this material. No part of this document may be reproduced, transmitted, transcribed, stored in a retrievable manner or translated into any language or computer language, in any form or by any means, electronic, mechanical, magnetic, optical, chemical, manual or otherwise, without the prior written consent of an officer of APRO Co., Ltd.

All parts of the APRO documentation are protected by copyright law and all rights are reserved.

APRO and the APRO logo are registered trademarks of APRO Co., Ltd.

Product names mentioned herein are for identification purposes only and may be trademarks and/or registered trademarks of their respective companies.

© 2023 APRO Corporation. All rights reserved