

# M116P

## 11.6" Rugged Tablet with Intel® Pentium® N4200



### KEY FEATURES

- Intel® Pentium® N4200 1.1GHz (Turbo up to 2.5 GHz)
- 11.6" 1920 x 1080 LED panel with direct optical bonding Rugged Tablet
- IP65 water and dust proof with MIL-STD-810G rugged housing
- Optional Integrated 1D/2D Barcode Reader and HF RFID for data collection
- Removable battery with hot-swap function for all day productivity
- 802.11ac WiFi, BT 5.0, 4G LTE, GPS Wireless Connectivity



### SPECIFICATIONS

Display			
<b>Bonding</b>	Optical Bonding for Sunlight Viewability	<b>Resolution</b>	1920x1080
<b>Size</b>	11.6 inches	<b>Contrast Ratio</b>	1000:1
<b>Panel Brightness</b>	850.0 nits	<b>View Angles</b>	85,85,85,85
<b>Type</b>	Projected Capacitive Multi Touch	<b>Viewability</b>	Anti-Glare touch treatment
<b>Touch Mode</b>	Support Hand/Rain, Stylus, Glove Mode		
System Specification			
<b>Processor</b>	Intel Pentium N4200 1.1GHz (up to 2.5GHz)	<b>Memory</b>	4GB LPDDR4 8GB LPDDR4 (Optional)
<b>Storage</b>	128 GB SSD Additional storage available with micro SDXC card slot 256 GB SSD (Optional) 512 GB SSD (Optional)	<b>Security</b>	Trusted Platform Module (TPM) 2.0 Kensington Lock
<b>Operating System</b>	Windows 10 IoT Enterprise (64 bit)	<b>WLAN</b>	Support
<b>BT</b>	Support	<b>WWAN</b>	4G LTE (Optional)
<b>GNSS</b>	GPS, GLONASS	<b>RFID</b>	HF RFID reader 13.56 MHz (Optional)
<b>Sensors</b>	Light sensor/ G-sensor / Gyro	<b>Smart Card Reader</b>	Smart Card Reader Comply with ISO7816-1.2.3 T=1 and T=Ø protocol (Optional)
Camera			
<b>Front Camera</b>	2MP front camera	<b>Rear Camera</b>	8MP rear camera with autofocus and LED light
Mechanical			
<b>Dimension</b>	300.67 x 201.97 x 22.5 mm	<b>Weight</b>	1.4 kg
<b>Cooling System</b>	Fanless design		
IO Ports			
<b>USB Port</b>	1 x USB 3.0 (Type A), 1 x USB 3.0 (Type C)	<b>SD Card Slot</b>	1 x Micro SDXC slot
<b>SIM Card Slot</b>	1 x Micro SIM card slot	<b>Video</b>	1 x Micro HDMI (Optional)
<b>Audio</b>	1 x Audio combo 3.5mm audio combo jack Built-in dual digital mic with noise cancellation 2 x 1 watt front-facing speakers	<b>LAN</b>	1 x RJ45-10/100/1000 GigaLAN port (Optional)
<b>Indicator</b>	4x LED Indicator for Power, Battery, HDD, RF status	<b>Docking Connector</b>	1 x 19-pin docking connector

Environment			
Operating Humidity	10% to 90% RH, non-condensing	Operating Temperature	-20°C to 60°C
Storage Temperature	-30°C to 70°C	Shock	MIL-STD-810G Method 516.6 Procedure I
Vibration	MIL-STD-810G Method 514.6 Procedure I	IP rating	IP65
Drop	MIL-STD-810G Method 516.6, 4 ft		
Certification			
Certification	CE, FCC		
Security Function			
SOTI MobiControl	SOTI MobiControl Compliance	Kensington Lock	Kensington Lock Support
Control			
Button	1 x Power, 3 x function keys		
Power			
Battery	Hot-swappable 7.7V typ. 5900 mAh Li-Polymer Battery (2S1P) Optional 7.4V typ. 10280 mAh Li-Polymer Battery (2S2P)	Battery Operating Time	Standard Battery: 8 hours
Power Rating	19V DC	Adapter	100-240V, 50-60Hz (19V DC)
Accessory			
Accessory	Adapter and Power Cord Capacitive Stylus Standard Battery	Optional Accessory	Desk Dock (Optional) Vehicle Dock (Optional) Vehicle Cradle (Optional) Vehicle Charger (Optional) Battery Charger (Optional) High Capacity Battery (Optional) Hand Strap (Optional) VESA Mount Kit (Optional) Shoulder Strap (Optional) Carry Bag (Optional)

Barcode Scanner	
Barcode Scanner	1D/2D barcode reader (Optional)

**DIMENSIONS** UNIT:MM

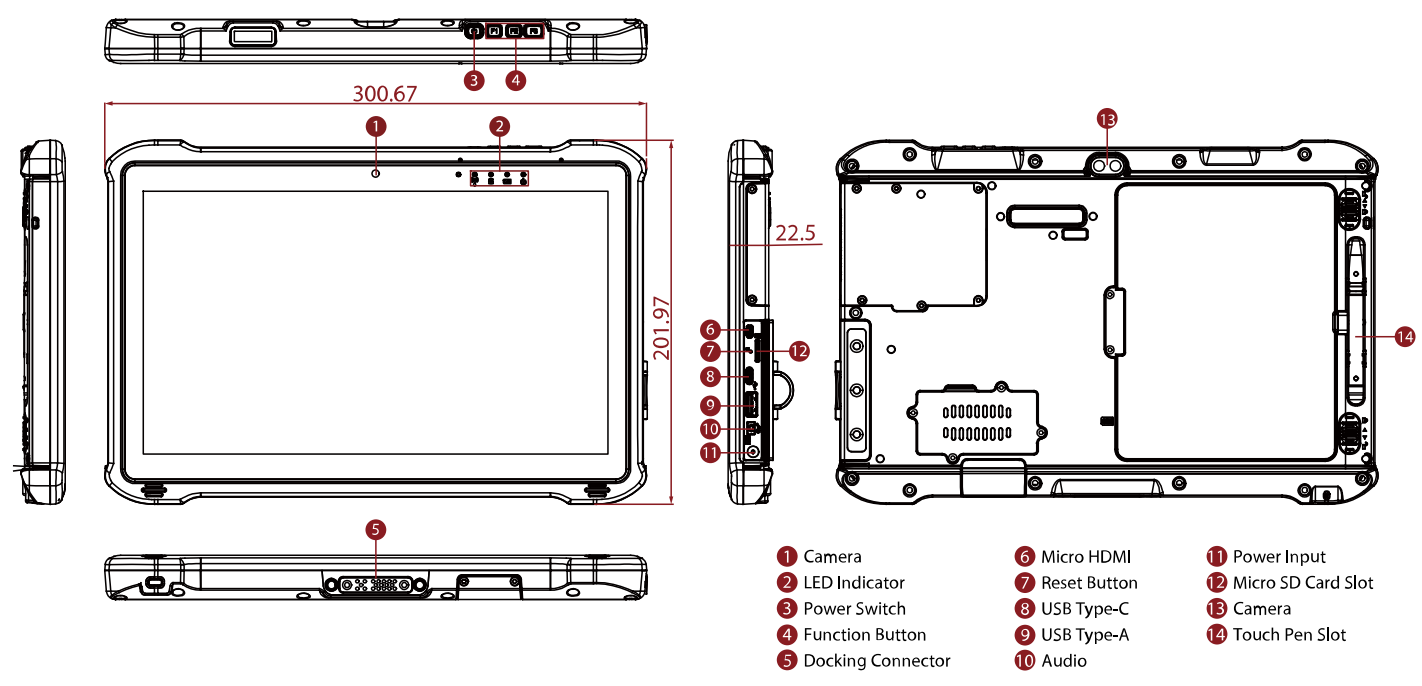

## NOTE

1. Total usable memory will be less dependent upon actual system configuration.
2. The USB Type-C connector follows USB 3.0 standard, which does not support Alternate Mode (ALT) or USB Power Delivery (USB-PD).
3. Add-on modules require the expansion port option to be usable.
4. TPM 2.0 is available upon request.
5. SOTI is available upon request.
6. Measured at dimming LCD brightness. Varies depending on the usage conditions, or when an external device is attached.
7. Length measurements do not include protrusions. Weight varies with options and active pen.
8. The product shown in this datasheet is a standard model. For diagrams that contain customized or optional I/O, please contact the Winmate Sales Team for more information.
9. This is a simplified drawing and some components are not marked in detail.