

SBC627

6U OpenVPX 5th Generation Intel® Core™ i7-based Single Board Computer

The SBC627 Rugged Single Board Computer (SBC) features the high performance, highly integrated 5th Generation Intel Core i7 processor platform, which offers integrated graphics and ECC memory controllers plus quad-core processing up to 2.7 GHz all in one device.

Coupled with the Mobile Intel QM87 Express Chipset this provides an unmatched level of I/O bandwidth for both on-board and off-board functions.

Features of the 5th Generation Core i7

- Graphics support for DX11.1, OpenCL 1.2, OpenGL 3.2
- 5 to 15% CPU performance boost over 4th generation
- Intel TurboBoost Technology
- Intel AVX 2.0 extensions and AES-NI instructions
- Hardware-assisted security features
- Hyper-Threading Technology – two threads per core

In addition to a comprehensive range of onboard I/O features, the SBC627 also offers on-board XMC mezzanine expansion sites for enhanced system flexibility. Memory resources include up to 32 GB DDR3 SDRAM with ECC, and 32 GB onboard SSD (NAND Flash).

The SBC627 is designed to meet the requirements of a wide range of applications from commercial and industrial through to fully rugged defense and aerospace programs. It offers extended temperature capability and a range of air- and conduction-cooled build levels.

A rich software choice is planned for the SBC627, including comprehensive Deployed Test Software (FSP-enabled BIT, and BCS) plus operating system support for Microsoft Windows 7, Open Linux (Fedora), Red Hat® Enterprise Linux, Wind River Linux, and VxWorks®. Examples and assistance are also available for integrating 'chain of trust' operation (from power-up to application start), plus Wind River's FSP-enabled VxWorks Boot Loader, into system scenarios.

FEATURES:

- SmartFusion2
- 6U OpenVPX single board computer
- 5th Generation Intel® Core™ i7
- Soldered DDR3 SDRAM with ECC
- Up to 64 GB solid state disk drive
- Up to 6 MB shared cache
- Multiple Data Plane Fabric Configurations (10/40GE)
- Multiple PCIe® Expansion Plane Fabric configurations
- Both rear & front I/O ports
- On-board expansion sites
- Trusted Platform Monitor (TPM)
- Elapsed Time Indicator (ETI)
- Rich software choice, including Deployed Test Software, plus operating systems support for Microsoft® Windows / Open Linux® and real-time operating system support

SBC627 6U OpenVPX 5th Generation Intel® Core™ i7-based Single Board Computer

Specifications

Processor

- Intel 5th Gen. Core i7 Processor, options include but are not limited to
- I7-5850EQ (Quad Core) @ 2.7 GHz (47W) (CPU speed is dependent on environment, consult manual for details)
- Last Level Cache
 - 6 MB

SDRAM

- Maximum memory configuration of up to 32 GB DDR3 SDRAM @ 1333/1600 MHz with ECC

Onboard Solid State Drive (SSD) (Optional)

- Up to 64 GB (2x 32 GB) NAND Flash

Plugin Modules (Optional)

- Rotating Media (750 GB minimum)
- SSD NAND Flash (60 GB minimum)

OpenVPX Module Profiles

- MOD6-PAY-4F1Q2U2T-12.2.1-8
- MOD6-PAY-4F1Q2U2T-12.2.1-13
- MOD6-PAY-4F1Q2U2T-12.2.1-15

USB Ports

- 6x USB 2.0 ports routed to P4/P6
- Up to 2x USB ports routed to front panel.
 - 1x USB 2.0 port
 - 1x USB 3.0 (optional) precludes use of XMC/PMC site 2

Expansion Plane

- x16 PCIe, 2 x8 PCIe, or 4 x4 PCIe from a Gen3 capable switch to P2 (1 port non-transparent capable)

Data Plane

- 2x 10/40 Gigabit Ethernet

Control Plane

- 2x 10/100/1000BASE-T – routed to P4
- 1x 10/100/1000BASE-T – routed to front panel (air-cooled only)

Management Plane

- IPMI (Baseboard Management Controller)

Serial Ports

- Three 16550 compatible serial ports
 - COM1 routed to P3 RS-232/422
 - COM2 routed to P4 RS-232/422
 - COM3 routed to front panel RS-232/422

Serial ATA

- 2x SATA 3 capable (6 Gb/s), routed to P6
- Optional 1x eSATA port routed to front panel (precludes use of XMC/PMC site 2)

Block diagram

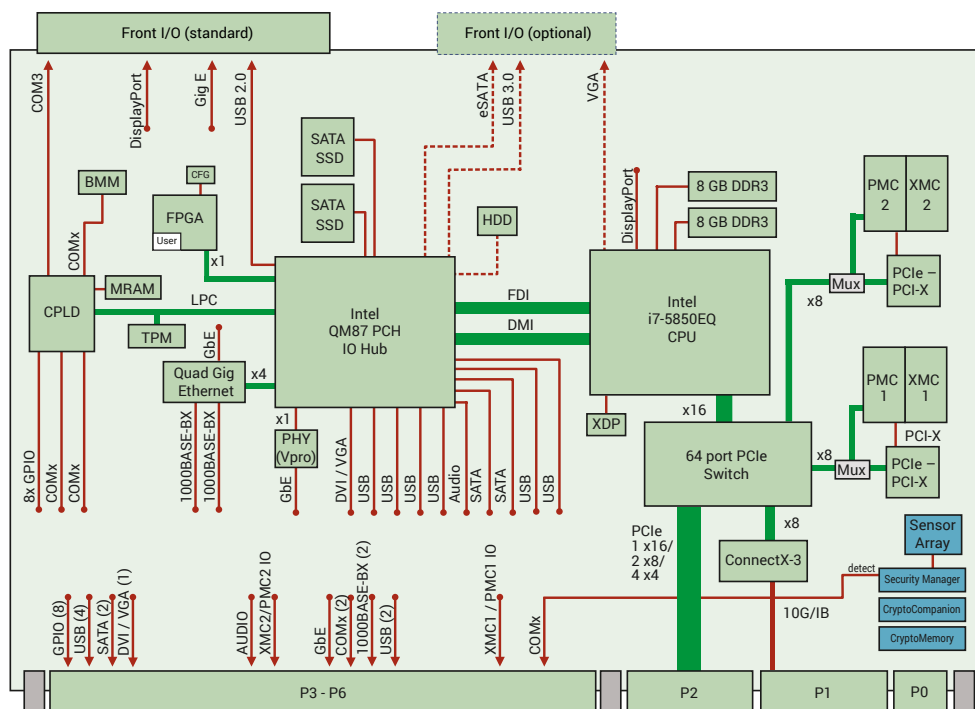

Video Controller

- 1x VGA port routed to P6
- 1x DVI/HDMI port routed to P6
- 1x DisplayPort routed to front panel
- 1x Front Panel VGA (optional) precludes use of XMC/PMC site 2

PMC / XMC Expansion Slots

- Both sites (one routed to P3/P4, one to P5/P6)
 - XMC - x8 PCIe Gen3
 - PMC - PCI-X 133 MHz
- Available with VITA 42 connectors (contact factory for VITA 61 connectors)

General Purpose I/O

- Up to 8x GPIO, 5V tolerant, each capable of generating an interrupt.

Audio

- High Definition Audio [routed to P5] with CODEC on RTM or other external sources.

LED

- 1x power
- 3x status LEDs and 4x BIT status (software control)

NVRAM / Watchdog / ETI / TPM

- 512kB non-volatile RAM (FRAM)
- Watchdog timer (software programmable)
- Elapsed Time Indicator
- Temperature Sensors
- TPM (Trusted Platform Module)
- Baseboard Management Controller (IPMI)

Power Requirements

- +12V, +5V and 3.3V_AUX

WE INNOVATE. WE DELIVER. YOU SUCCEED.

Americas: 866-OK-ABACO or +1-866-652-2226 | Europe, Africa, Middle East, & Asia Pacific: +44 (0) 1327-359444

abaco.com

Abaco Systems is a global leader in commercial open architecture computing and rugged embedded electronics. With more than 30 years of experience in aerospace & defense, industrial, energy, medical, communications and other critical sectors, Abaco's innovative solutions align with open standards to accelerate customer success.

Abaco Systems is a business unit of AMETEK, Inc. is a leading global provider of industrial technology solutions serving a diverse set of attractive niche markets with annual sales over \$6.0 billion.

