

W24L100-MLL1FP

23.8" 4K2K UHD Defence Display



KEY FEATURES

- 23.8" 4K2K UHD PCAP Rack Mount Defence Display (3840 x 2160) native resolution
- Compliant MIL-STD 810G/ MIL-STD 461E
- Rack mount mechanical design, supports VESA mount
- PCAP multi-touch screen
- Defence-grade power connector (MIL-DTL-38999/1)
- AC 100~240V, Universal, $\pm 10\%$; DC 9~36V, $\pm 10\%$ (Optional)
- Convenient on-screen display controls



SPECIFICATIONS

Display			
Touch / Glass	Projected Capacitive Multi Touch Screen PCAP with With ITO Flim (Optional)	Resolution	3840x2160
Size	23.8 inches	Contrast Ratio	1200:1
Panel Brightness	540 nits	Display Color	1.07B Colors
View Angles	89,89,89,89	Active Area	525.65x295.70 mm
Environment			
Operating Humidity	10% to 95% RH	Operating Temperature	0~50°C
Storage Temperature	-25°C~60°C		
Compliance			
MIL-STD 461E/F	RE101 / RE102 CE101 / CE102 with EMI Glass / Touch(Optional) RS101 / RS 103 CS101 / CS 106 / CS 109 / CS 114 / CS 115 / CS 116	MIL-STD 810F/G	Vibration Method 514.5 Humidity Method 507.4 Transit Drop Method516.5
Certification			
Certification	CE, FCC		
IO Ports			
USB Port	1 x USB for Touch Screen (Optional)	Serial Port	1 x RS232 for Remote Control (Optional)
Video	1 x VGA 1 x DVI 1 x Display Port 1.2 1 x HDMI 1.4 (Optional) 1 x HDMI 2.0 (Optional)	Audio	1 x Audio Line In (Optional)
Mechanical			
Dimension	630 x 430.5 x 66 mm	Weight	13Kg
Mounting	VESA Mount/ Rack Mount	Enclosure	Metal
Cooling System	Fanless Design		
Accessory			
Accessory	1 x User Manual(Hardcopy)	Optional Accessory	1 x Auido cable

- 1 x Power Cord MILDTL38999/1
- 1 x VGA Cable
- 1 x DVI Cable
- 2 x HDMI Cable
- 1 x DP Cable

Power

Power Rating	AC 100~240V, Universal, ±10% DC 9~36V, ±10% (Optional)
---------------------	---

Control

Button	7 key: Power Decrease Increase Exit/ Auto Menu Day/ Night Lock/ Unlock
---------------	---

DIMENSIONS UNIT:MM

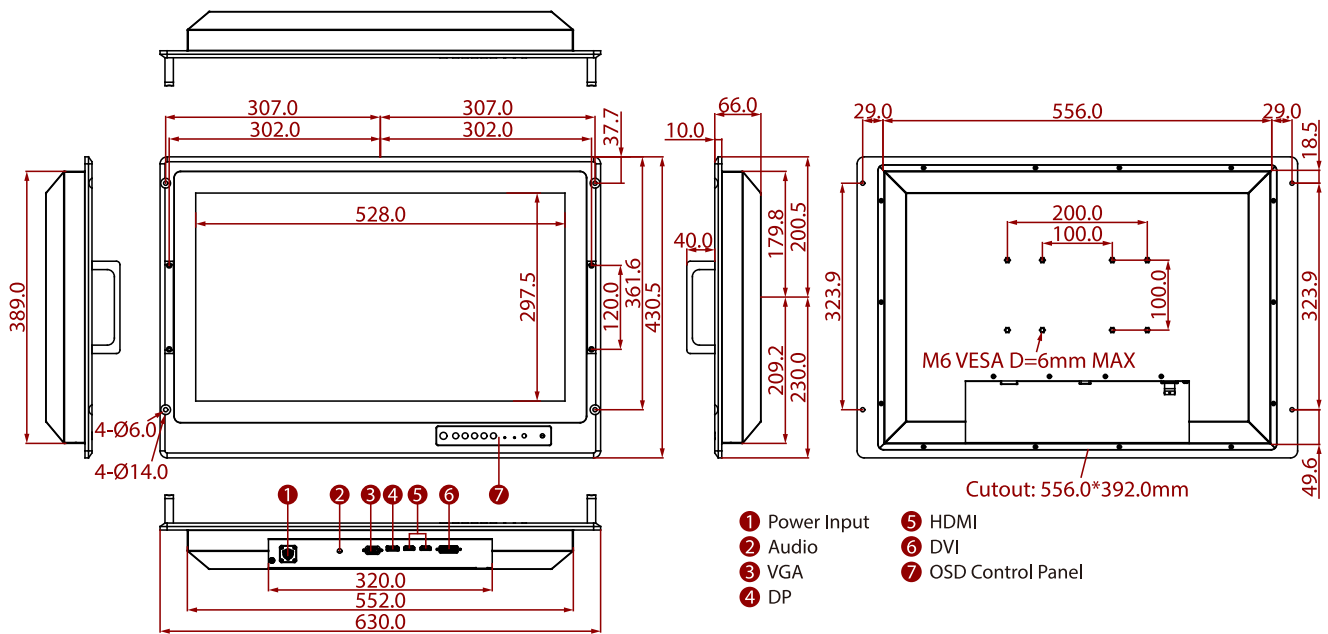

NOTE

1. This is a simplified drawing and some components are not marked in detail.
2. If you require an external test report, Winmate will charge an NRE fee.
3. Please contact our sales representative if you need further product information.
4. All specifications are subject to change without prior notice.
5. The product shown in this datasheet is a standard model. For diagrams that contain customized or optional I/O, please contact the Winmate Sales Team for more information.