

AI Inference / DeviceEdge

Jetson Platform AX720-X32/X64



Features

- Specifically designed for high performance and low-power envelope AI computing.
- Additional driver to support Embedded peripheral modules for multiple I/O expansion capability.
- On-board 2x HDMI, 1x M.2 M Key, 1x M.2 E Key and 3x RJ45 to support rich multimedia.
- Extended temperature range -40°C to 80°C
- 9 to 20VDC power input

Specifications

Model Number	AX720-X32	AX720-X64
Module Compatibility	NVIDIA Jetson AGX Xavier 32GB	NVIDIA Jetson AGX Xavier 64GB
AI Performance	32 TOPs	
GPU	512-core NVIDIA Volta™ GPU With 64 Tensor Cores	
CPU	8-core NVIDIA Carmel Arm®v8.2 64-bit CPU 8MB L2 + 4MB L3	
Memory	32 GB 256-bit LPDDR4x 136.5GB/s	64 GB 256-bit LPDDR4x 136.5GB/s
Storage	32 GB eMMC 5.1	
Display	2x HDMI Type A	
Audio	HDMI Integrated	
Camera Input	1x 16-Lane MIPI Expansion Connector, Compatible With AGX Xavier Development Kit	
LAN	3 x RJ-45 GbE Ports (1x Onboard, 2x Extension Adapter)	
USB	2 x USB 3.2 Gen1 Type A 1x USB3.2 Gen2 Type C 1x USB2.0 AB OTG	
I/O Interfaces	1 x RS-232, 2 x UART1 / UART2, 1 x UART3 (Debug Only), 2 x CAN 2.0b, 5 x GPIO, 1 x I ² C, 1 x SPI	
Expansion	1 x M.2 E-Key 2230 (PCIe/USB2.0): Support WIFI/BT Module 1 x M.2 M-Key 2280: Support NVMe Storage 1 x MicroSD Slot	
MISC. Function	1 x Power/Recovery/Reset Button	
Power Consumption	Idle: 3.63W (Connect With Keyboard, Mouse and HDMI Display) Full Loading: 27.48W (Connect With Keyboard, Mouse and HDMI Display With CPU And GPU 100% Loading)	
Power Input / Connector	DC-in 9 to 20VDC / 6-pin ATX Power Connector	
Dimension (W x D x H)	131 x 120 x 30.5 mm (5.16" x 4.73" x 1.20")	
Net Weight	640g (with Fansink)	
Temperature	Operating Temp.: -20°C ~ + 80°C (-4°F~176°F) / Storage Temp.: -40°C ~ + 85°C (- 40°F ~185°F)	
Humidity	95% @ 40°C Related Humidity, Non-condensing	
OS Support	Ubuntu 18.04	
Certification	CE/FCC Class A	

System & Mounting Dimensions

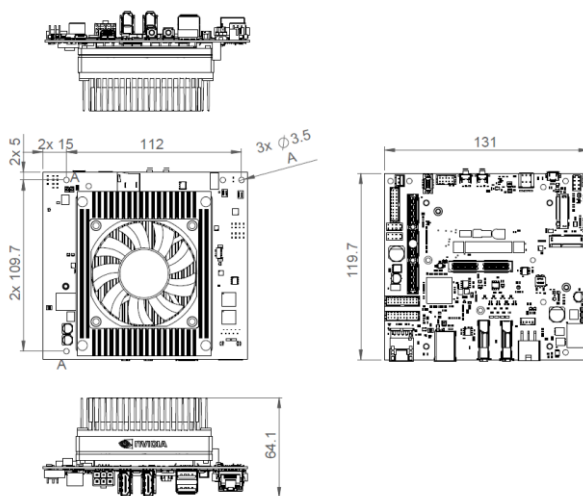

I/O Mechanical Layout

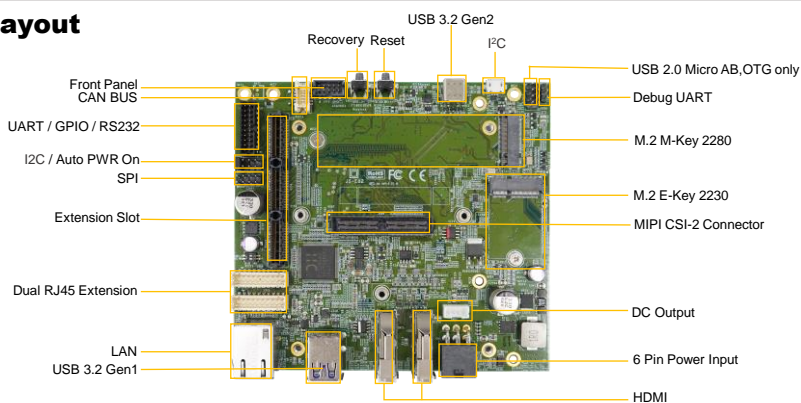

Ordering Information

Model name	Carrier w/AGX Xavier Module	Fansink	Cable Kit	PWR Adapter	US PWR Cord	EU PWR Cord	2 LAN Module	Power Cable
AX720-X32-FN01	32GB	-	-	-	-	-	v	v
AX720-X32-FN02	32GB	v	v	v	v	-	v	v
AX720-X32-FN03	32GB	v	v	v	-	v	v	v
AX720-X32-FN04	32GB	v	-	-	-	-	v	v
AX720-X64-FN01	64GB	-	-	-	-	-	v	v
AX720-X64-FN02	64GB	v	v	v	v	-	v	v
AX720-X64-FN03	64GB	v	v	v	-	v	v	v
AX720-X64-FN04	64GB	v	-	-	-	-	v	v

Packing List

Part Number	Description
AX720-X32/X64	
39-C16161-0000	Fan with Heatsink
31-080000-0002	Cable Kit (CAN bus / UART / RS232 / Front panel / GPIO / I2C)
53-0MSBTG-0000	2x LAN Daughter Board
53-0F0000-0004	Power Adapter 100-240V 120W 19V 6.32A
32-010000-0006	EU Power Cord (1800mm)
32-010000-0005	US Power Cord (1800mm)
32-010000-0008	JP Power Cord (1800mm)
31-030000-0005	Power Cable DC Jack 2.5mm to 2x3P 4.2mm Housing (100mm)

Accessory (Optional)

Part Number	Description
53-0G8265-0000	Intel AC8265.NGWMG WiFi/Bluetooth Module

