

EPSM-10GX4 Compact Managed 28-Port Rugged Gigabit Ethernet Switch Module

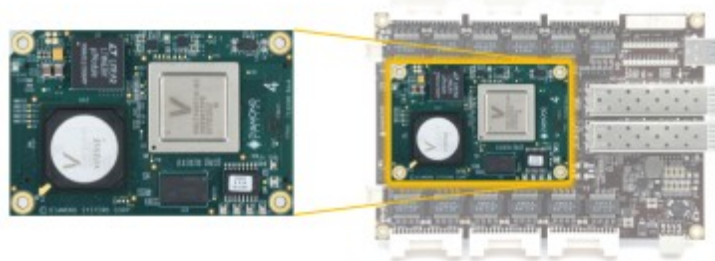

Speeds up design of custom Ethernet switch boards and systems

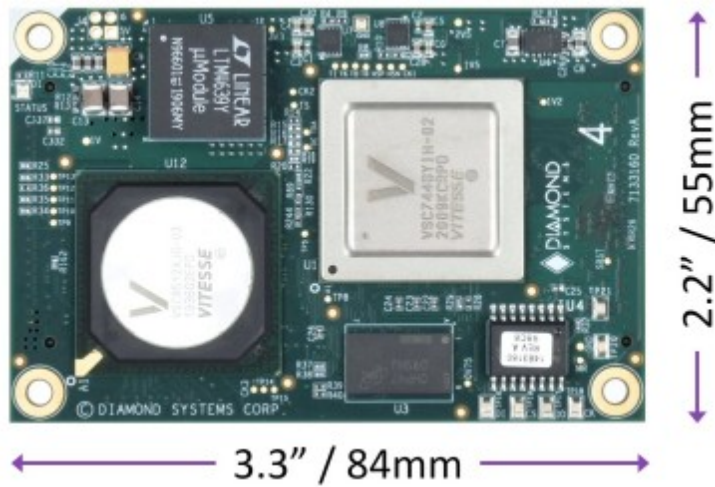
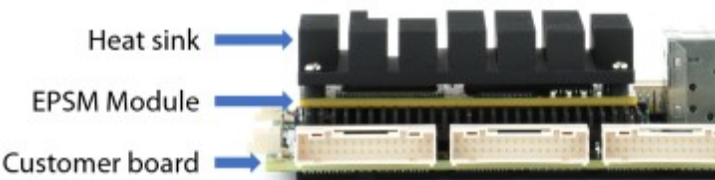

FEATURES

- COM-like virtually-complete Ethernet switch with embedded software on a compact module
- Enables rapid development of custom Ethernet switch boards and systems
- Only magnetics, connectors, and input voltage regulator needed to create complete solution
- 24 total gigabit Ethernet ports – 12 from on-board PHY, 12 from carrier board PHY
- 4 10G SFI ports for SFP+ or rugged optical transceivers
- High speed connectors carry all signals to carrier board
- Only 55 x 84mm / 2.2 x 3.3", same size as a business card
- Thicker PCB and -40 to +85°C operating temperature support rugged mobile applications
- Heat sink and heat spreader thermal solutions and design files available
- Layer 2+ switching and Layer 3 routing software available
- IEEE 1588 PTP support available
- Design kit available with carrier board schematics and bill of materials
- Custom carrier board and complete switch solution design and manufacturing services available

◆ Description

The EPSM-10GX4 is a managed Ethernet switch module in an ultra-compact 2.2" x 3.3" (55 x 84mm) size offering 24 10/100/1000Mbps copper ports + 4 10Gbps SFI ports. The module is intended to be used on a carrier board, such as Diamond's **EPS-24G4X**, to implement a complete Ethernet switching solution. The core Ethernet switching technology is almost fully encapsulated on the module; for many applications,

only the "last inch" of magnetics and I/O connectors is required to complete the circuit, enabling easy development of custom form factor compact, rugged Ethernet switch solutions.

The small size, based on the industry-standard COM Express Mini form factor, makes EPSM-10GX a perfect choice for use as a building block for creating custom Ethernet switch solutions in a variety of space-demanding applications, such as drones, ground and underwater vehicles, and robots.

Customers looking for a complete off-the-shelf solution may be interested in our EPS-24G4X, which provides all of the switch's features in the industry standard 3.5 inch form factor with integrated latching I/O connectors and SFP+ sockets. Diamond Systems also offers custom carrier board design services to provide a perfect fit solution for your application.

Two software packages are available, Layer 2+ switching and Layer 3 routing/switching. In addition, IEEE-1588 precision time protocol support is available with a minor modification to support an external precision clock circuit and 1pps signal source provided by the carrier board. All software features are manageable via a GUI web interface accessible over any port, as well as with a command language accessed via a built-in RS-232 port.

Two cooling accessory options are available: A heat sink provides convection cooling in a low profile, while a heat spreader provides improved conduction cooling for superior high temperature performance in applications where physical contact with the system enclosure is available.

Two high-speed fine-pitch connectors provide all power and data communications between the module and the carrier board. The first connector provides power, 9 10/100/1000 ports, the serial interface, and a serial LED data stream. Applications requiring 9 ports or less may use just this connector. The second connector contains 3 more 10/100/1000 ports, QSGMII signals for an additional 12-port PHY to provide 12 additional 10/100/1000 ports, and the 4 10G SFI ports.

EPSM-10GX4 is designed to meet the challenges of vehicle environments with its 50% thicker PCB, -40/+85°C operating temperature range, and MIL-STD-202G shock/vibration resistance.

◆ Block Diagram

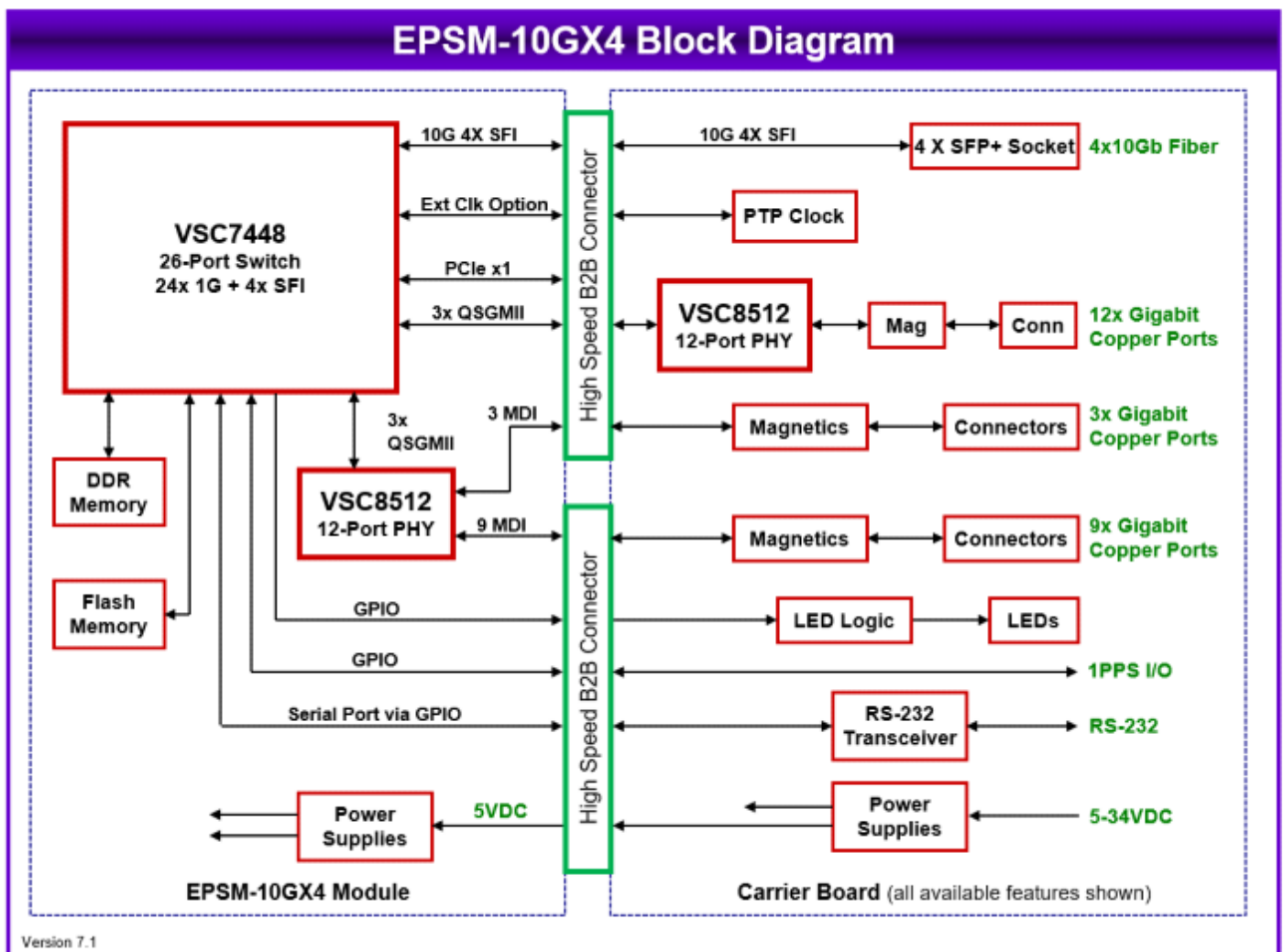

◆ Embedded Software

Two software packages are available for EPSM-10GX4, Layer 2+ switching and Layer 3 routing/switching. In addition, IEEE-1588 precision time protocol support is available with a minor modification to support an external precision clock circuit and 1pps signal source provided by the carrier board. All software features are manageable via a GUI web interface accessible over any port, as well as with a command language accessed via a built-in RS-232 port.

The table below shows some of the more popular features available. For a complete list of features available in each software package, [click here](#).

Layer 2+ software highlights include the following:

8K MAC addresses and 4K VLANs (IEEE 802.1Q)

8K IPv4 and IPv6 multicast group support

Jumbo frame support at all speeds

Flexible link aggregation support based on Layer-2 through Layer-4 information (IEEE 802.3ad)

Multicast and broadcast storm control, as well as flooding control

Rapid Spanning Tree protocol (RSTP) and MSTP

Multiple protocol support: IEEE 802.1d, IEEE 802.1w, IEEE 802.1s, and IEEE 802.1X

8 priorities and 8 QoS queues per port with scheduling

Layer3 software additional highlights:

Hardware- and software-based IPv6 L3 static routing

RFC 2328 OSPFv2 dynamic routing

IEEE 1588 precision time protocol (PTP)

RADIUS accounting

Port and Queue policers

◆ Cooling Options

Both heat sink and heat spreader cooling options are available. The heat spreader is the preferred choice for applications where the packaging design permits its use. It includes an integrated thermal pad for improved contact with the enclosure wall. For customer's designing their own cooling solutions, Diamond can provide 3D files and other design support.

◆ Development Support

A design guide is available with circuit details and other technical information necessary to design a carrier board around the EPSM-10GX4. A complete development kit is also available including the technical design package (schematics, PCB layout, and BOM) of our EPS-24G4X carrier board, along with a complete EPS-24G4X switch and cable kit. Contact Diamond Systems for further information and ordering instructions.

◆ Custom Carrier Board Design

Diamond Systems engages in the design and manufacturing of custom carrier boards for various computing technologies, including COM Express, Nvidia Jetson GPU modules, and Ethernet switch modules. Contact us to learn more about how we can provide a cost-effective, low-risk, quick time to market solution for your Ethernet switch project using the EPSM-10GX4 switch module and a custom carrier board that fits your exact needs.

◆ Specifications

Number of Ports	24 10/100/1000Mbps Ethernet ports with non-blocking wire-speed performance 4 10G SFI ports for fiber or copper transceivers Magnetics and 10G transceivers required on carrier board
Implementation	12 PHYs integrated on main board; QSGMII signals for additional 12-port PHY on carrier board
On-board Memory	4MB packet memory
Network Management	SNMP v1/v2c/v3; Web GUI and command line interface (CLI)
Power Management	ActiPHY and PerfectReach power management reduce power for shorter cable lengths and shut down power to disconnected ports

Serial Port	1 serial port for host interface; RS-232 transceiver required on carrier board
Indicator lights	Serial data stream provided for 2 LEDs per port; decoder logic required on carrier board
Form Factor	55x84mm / 2.17x3.31" (Same as COM Express Type 10)
Interconnect	Dual Samtec ERF5 series connectors, 120 pins each, 10mm board to board spacing
Input voltage	5VDC +/-5%
Power consumption	20W max, all ports active
Operating temperature	-40 to +85°C with DSC-provided heat sink or heat spreader
Cooling	Heat sink, 55x84mm, 16.6mm height Heat spreader, 55x104mm, 7.6mm height
Weight	85G / 3.0 oz
Rohs	Compliant

◆ Models and Accessories

EP SM-10GX4

available models:

EP SM-10GX4	Miniature Ethernet switch module with 24 1G ports, 4 10G ports, and Layer 2+ management software	Available
EP SM-10GX4-1588	Miniature Ethernet switch module with 24 1G ports, 4 10G ports, and Layer 3 management software with routing support, IEEE-1588 PTP ready	Available
EP SM-10GX4-L3	Miniature Ethernet switch module with 24 1G ports, 4 10G ports, and Layer 3 management software with routing support	Available

Please [login](#) or [signup](#) for an online quote request.

www.diamondsystems.com | [Sunnyvale, California USA](#) | [+1-650-810-2500](tel:+16508102500) | sales@diamondsystems.com