



STV-BB01 full feature model



STV-BB03 low cost model

FEATURES

On-board features:

- 2x USB 3.1
- 2x USB 2.0
- 1-2 Gigabit Ethernet
- 2x HDMI
- 2-4 RS-232/422/485
- 2x CAN
- Audio
- 6 12-bit ADC + 2 12-bit DAC + 13 GPIO 3.3V or 16 GPIO

Socketed features:

- Camera module connector with 4x4 CSI lanes supporting up to 8x 2-lane CSI cameras
- UFS flash socket + Micro SD
- M.2 PCIe x4 2280 socket
- mPCIe socket with PCIe and USB
- Input voltage 9-20VDC
- Size: 3.62" x 4.17" / 92mm x 106mm
- Operating temperature: -40 to +85C



**STV-AGX32-01 includes AGX Xavier module
installed underneath and programmed with Linux
OS**



**Top side with connectors and camera adapter
socket**



Module side with Xavier socket and M.2 socket

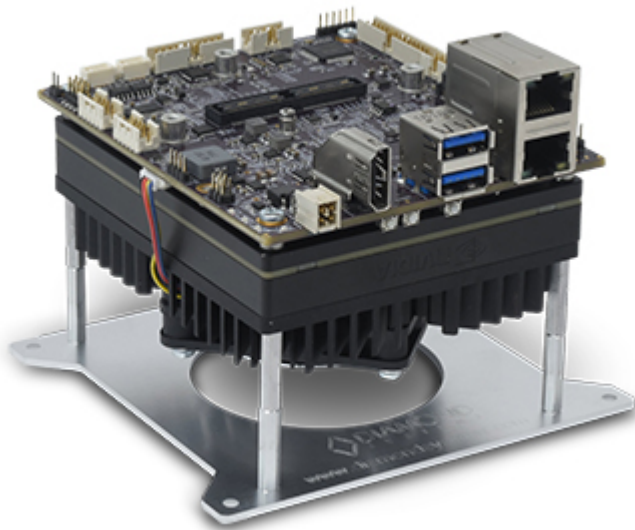

Development kit NDK-STV-0030 with carrier, module, OS installed, fan sink, and mounting platform

STEVIE is a compact, low-cost, feature-packed carrier board solution for the NVIDIA Jetson AGX Xavier computer module. STEVIE measures 92 x 106mm (3.62 x 4.17"), just slightly larger than the AGX Xavier module (87 x 100mm). This small outline enables Stevie to provide the maximum amount of I/O and support full-size 2280 M.2 modules in the smallest possible size.

The most popular I/O is located along the front edge of the board using commercial style panel I/O connectors. This facilitates installation in an enclosure with fewer internal cables, helping to further reduce overall system cost and size.

PCIe Minicard and M.2 sockets enable the installation of flashdisk and I/O expansion module to customize Stevie to your particular application requirements.

STEVIE is available in three models. STV-BB01 is the full feature model. STV-BB02 is the same as BB02 but has just one Ethernet port. STV-BB03 is a cost reduced model with fewer I/O features

and a lower height single Ethernet jack.

STEVIE is ideal for NVIDIA Jetson Xavier applications in typical commercial / industrial environments requiring low cost and compact size. For mobile and outdoor applications requiring a higher degree of ruggedness or more advanced I/O, see our **ELTON** carrier with PCIe/104 I/O expansion.

◆ Available Models

The table below lists the I/O features of the available Stevie configurations. In all respects not listed, all models are identical.

Model	STV-BB01	STV-BB02	STV-BB03
Description	Full featured model	Single Ethernet model with all other features	Cost reduced model
Ethernet	2 Gigabit Ethernet using dual stacked RJ-45 jack	1 Gigabit Ethernet using dual stacked RJ-45 jack; one port inoperative	1 Gigabit Ethernet using single RJ-45 jack
Serial ports	4 RS-232/422/485	4 RS-232/422/485	2 RS-232/422/485
Data Acquisition	Microcontroller with 6 ADC, 2 DAC, 13 GPIO	Microcontroller with 6 ADC, 2 DAC, 13 GPIO	I2C GPIO expander with 16 GPIO lines
USB	2x USB 3.1, 2x USB 2.0	2x USB 3.1, 2x USB 2.0	2x USB 3.1, 2x USB 2.0
HDMI	2	2	2
CAN	2	2	2
Audio	Yes	Yes	Yes
M.2 socket	NVMe x4 2280	NVMe x4 2280	NVMe x4 2280
Mini PCIe socket	1 with PCIe and USB	1 with PCIe and USB	1 with PCIe and USB
Micro SD	1 Micro SD + UFS	1 Micro SD + UFS	1 Micro SD + UFS

◆ Stevie Block Diagram

STEVIE - NVidia AGX Xavier Carrier - Block Diagram

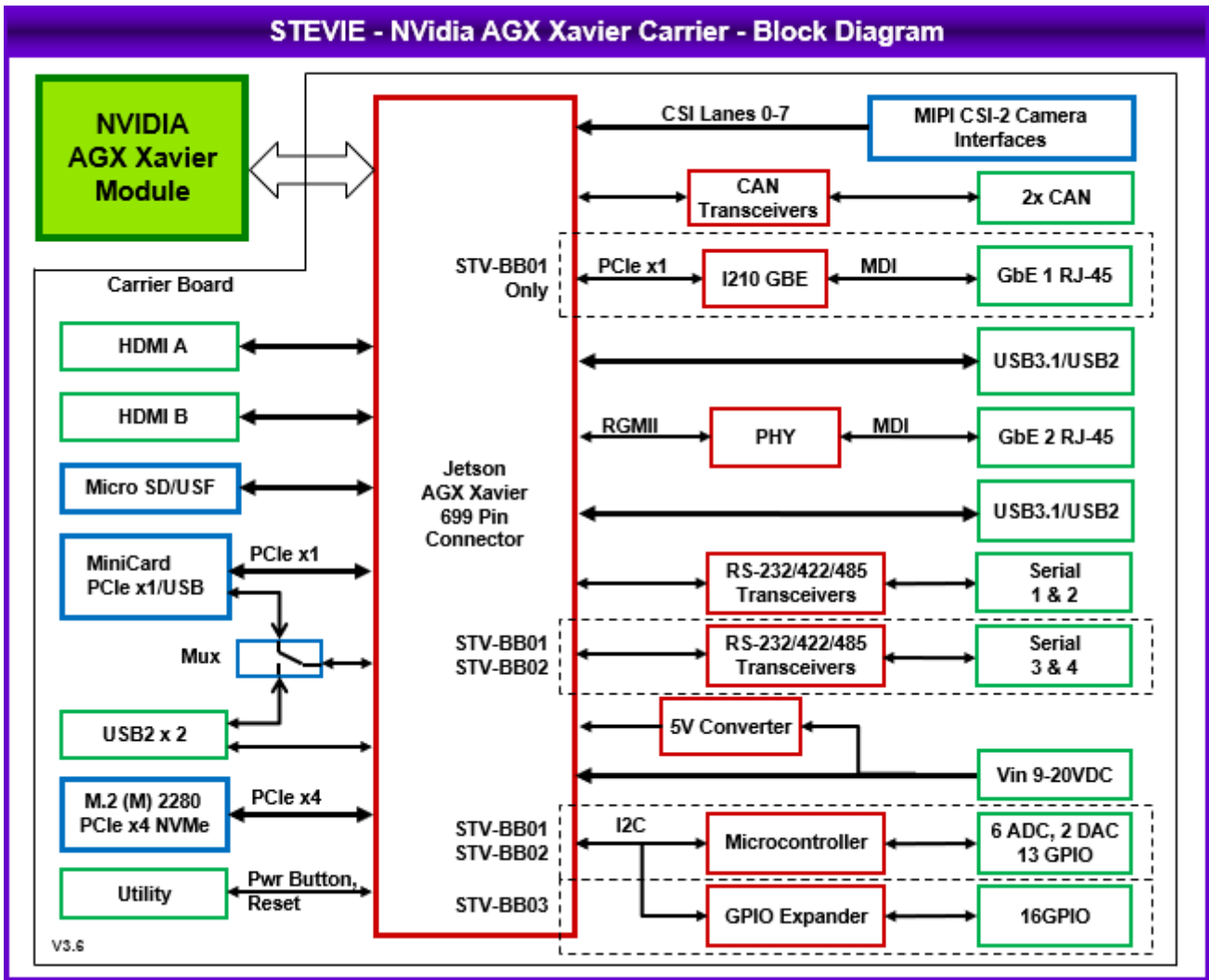

◆ Data Acquisition

A built-in data acquisition circuit provides 12-bit A/D up to 1MSPS, 12-bit D/A, and 3.3V GPIO. Diamond's free C-language programming library simplifies application development, while a GUI control panel offers convenient control and monitoring of real-world processes as well as ready-to-run data logging capability.

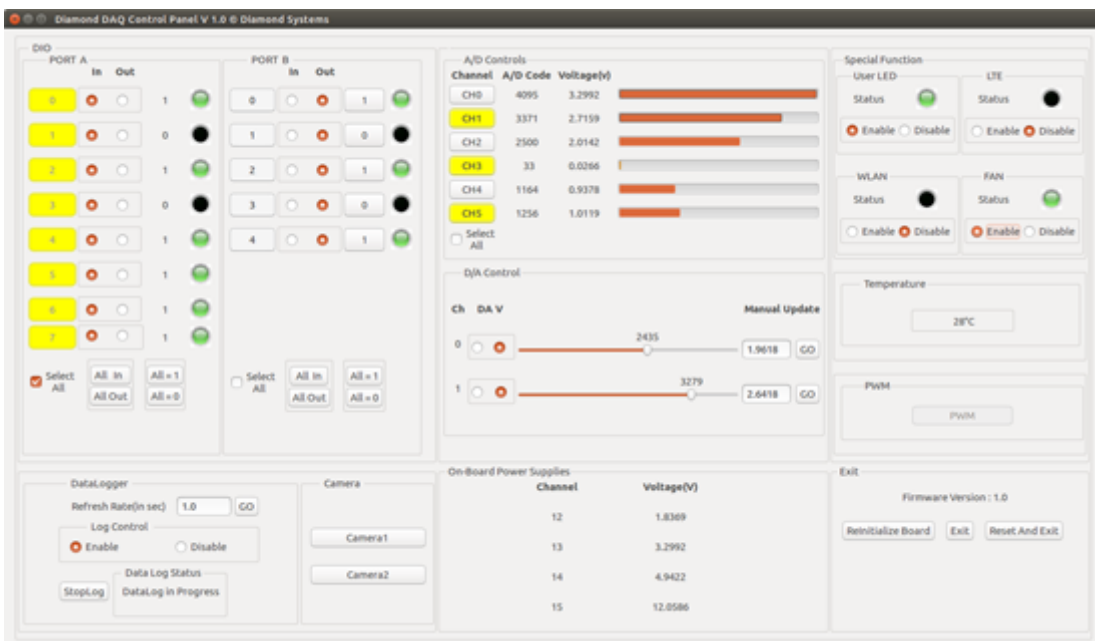

◆ Cable Kit

◆ Stevie Cable Kit

Cable kit CK-STV-01 contains all cables needed for the I/O pin headers and power connector on Stevie. Generic commercial-style cables (Ethernet, USB, HDMI) are not included.

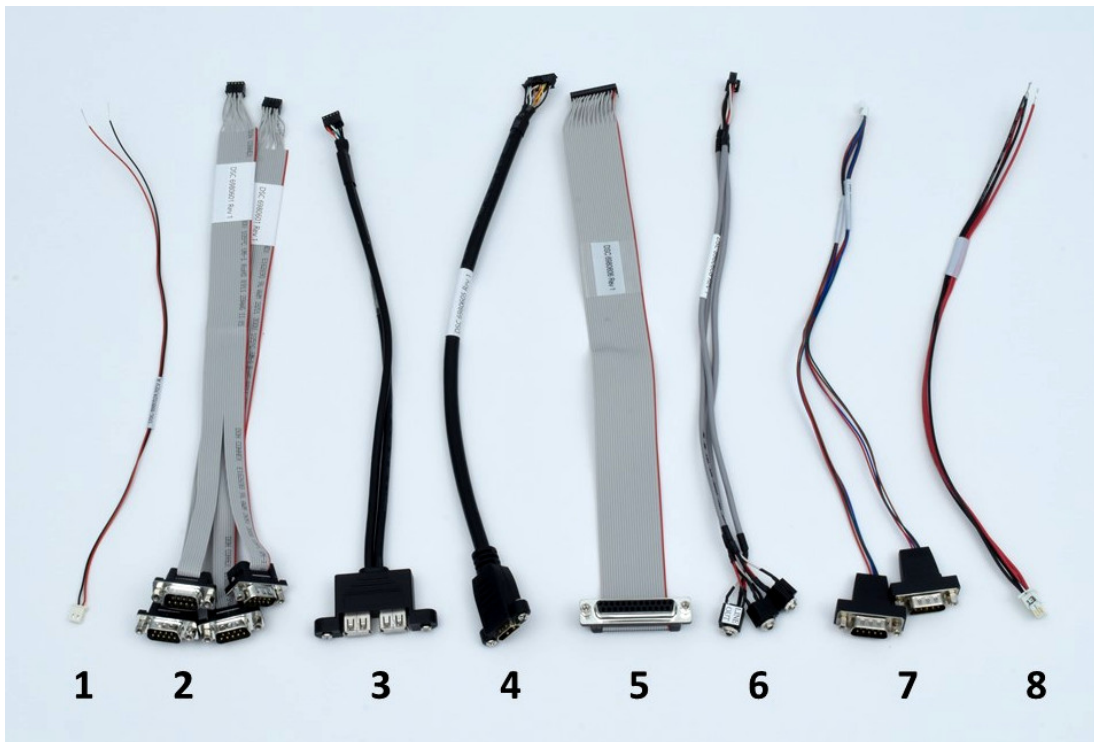

CK-STV-01 includes the following cables:

No.	Qty	Cable	Description	Drawing
1	1	6980524	External battery cable, discrete wires	Show
2	2	6980601	Dual serial port cable, 2x DB9 male	Show
3	1	6980602	Dual USB 2.0 cable, 2x USB 2.0 type A	Show
4	1	6980605	HDMI Cable	Show
5	1	6980606	DAQ Cable	Show
6	1	6980608	Audio cable, 3x 3.5mm jacks	Show
7	2	6981182	CANbus 2.0 cable, JST 1x4 to DB9M	Show
8	1	6981507	Power Cable, IPD 2x2 to Leads, 20AV	Show

◆ System Solutions

◆ JetBox Stevie Systems

Stevie is available as a complete system, with the AGX Xavier 32GB module installed and preprogrammed with Diamond's customized Linux OS for Jetson, all assembled into a sturdy steel and aluminum enclosure. The enclosure provides access to all the front edge I/O connectors plus 4 additional DB9 connectors (serial ports and/or CAN), the second HDMI port, 2 USB 2.0 ports, and up to two SMA type antenna connectors for an installed M.2 or Minicard module. To learn more about these systems [click here](#).



◆ Development Kit

The Stevie Development Kit **NK-STV-0030** is a special kit created for the Nvidia Jetson developer community that provides a complete platform for AGX Xavier application development. The kit consists of a Stevie carrier board with AGX Xavier 32GB module mounted and the latest Jetpack Linux OS installed. A heat sink with fan provides safe cooling for high power conditions. The complete system is mounted on a convenient mounting plate that can be used on a benchtop or affixed to an enclosure surface. A cable kit and 12V AC adapter are also included. the Stevie dev kit is plug and play - simply take it out of the box, attach keyboard/mouse/display, power up, and you're ready to go.

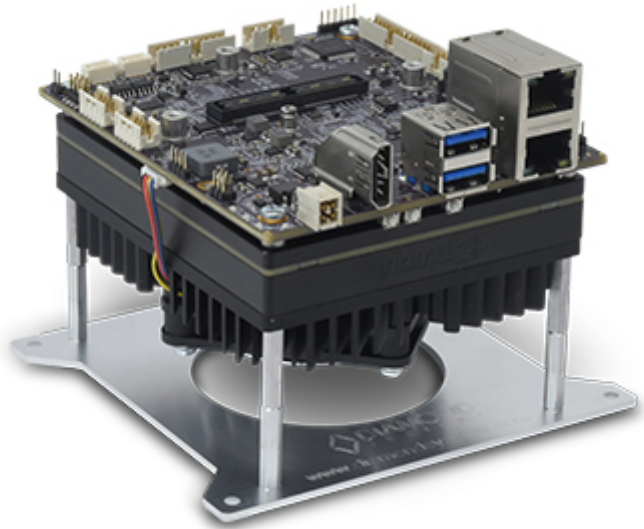

◆ Ordering Information

◆ Models and Accessories

STEVIE

available models:

STV-BB01	STEVIE carrier board for AGX Xavier, full feature model	Available
STV-BB02	STEVIE carrier board for AGX Xavier, single Ethernet port	Min Order Quantity
STV-BB03	Stevie Carrier for Nvidia Jetson AGX Xavier, Economy Model	Available
STV-AGX32-01	Stevie BB01 carrier with AGX Xavier 32GB module installed and programmed	Available
STV-AGX32-02	Stevie BB02 carrier with AGX Xavier 32GB module installed and programmed	Min Order Quantity
STV-AGX32-03	Stevie BB03 carrier with AGX Xavier 32GB module installed and programmed	Available
NDK-STV-0030	Stevie AGX Xavier Development Kit: STV-BB03 with AGX Xavier 32GB module, OS installed, Fan sink, Mounting plate	Available
ACC-HSSTV-01	Heat Sink With Fan for AGX Modules, 87x100mm, 5V 4-Pin Fan Connector	

Please [login](#) or [signup](#) for an online quote request.

◀ **Cables and accessories** ▶

available models:

CK-STV-01 CK-STV-01 cable kit

Please [login](#) or [signup](#) for an online quote request.

www.diamondsystems.com | [Sunnyvale, California USA](#) | [+1-650-810-2500](tel:+16508102500) |
sales@diamondsystems.com