

NVIDIA® TESLA® PASCAL™ P6, 6 TFLOPS with HPC Mode and GRID™ vGPU

KEY FEATURES

- NVIDIA Tesla P6 16nm FinFET GPU
- 6 TFLOPS, 2048 CUDA® core GPGPU Engine
- High Performance Compute (HPC) mode
- NVIDIA GRID™ vGPU virtualization with up to 16 vGPU instances
- Operating power configurable hard cap: 40 – 90W

ADDITIONAL FEATURES

- 16 GB GDDR5 memory with NVIDIA GPUDirect™ DMA technology
- Error Correcting Code (ECC) to protect against memory errors
- Pascal GPGPU parallel processing:
 - 2048 CUDA® cores
 - CUDA Toolkit 9, CUDA Compute version 6.1
 - OpenCL™ 1.2, DirectX® 12, OpenGL 4.5
 - Vulkan 1.0
- Memory width: 256-bit width
- Maximum memory bandwidth: 192 GB/s
- PCIe x16 Gen3
- NVENC/NVDEC accelerator for HEVC (H.265) and AVC (H.264) hardware encode/decode
- Windows and Linux drivers

SPECIFICATIONS

- High level of ruggedization:
 - Rugged air-cooled or conduction-cooled
 - Operating temperature: -40° to +65°C (system dependent)
 - Vibration (sine wave): 5G peak, 5 - 2000Hz
 - Shock: 20G peak
- Supported VPX configurations:
 - VPX-REDI (ANSI/VITA 48.x)
 - OpenVPX (ANSI/VITA 65)

OVERVIEW

The VPX3U-TESLA-P6-HPC board uses NVIDIA's advanced Tesla Pascal 16nm GPU technology. This rugged Pascal-based board runs in NVIDIA's HPC mode which exposes a large memory base address register (BAR) for direct access to the GPU memory from the CPU and other PCIe devices.

The Tesla P6 includes support for NVIDIA GRID, the industry's most advanced technology for sharing true virtual GPU (GRID vGPU) hardware acceleration between multiple users. This technology ensures complete application compatibility, which means features and experience are the same as they would be on a physical device.

The rugged VPX3U-TESLA-P6-HPC board includes air-cooled and conduction cooled options. For additional options contact WOLF to discuss MCOTS and custom design services.



WOLF- 1116 VPX Module

NVIDIA TESLA PASCAL P6

Tesla Pascal P6 is an enormous leap in processing power compared to the previous generation Maxwell Tesla M6. Each GPU can provide up to 6 TFLOPS of CUDA processing at maximum operating power, providing a huge improvement to 67 GFLOPS/Watt, making it an excellent choice for aerospace and defense applications. With its impressive processing capabilities the board excels at data processing which benefits from advanced parallel processing and TFLOPS of processing speed, such as ISR (intelligence, surveillance and reconnaissance), C⁴ISR (command, control, communications, computers ISR), image processing, terrain analysis, object tracking or 3D visualization of geospatial data.

Tesla Pascal GPU architecture also provides a more powerful Unified Memory feature. Pascal's larger virtual memory address space enable GPUs to access the entire system memory plus the memory of all GPUs in the system, while the on-demand page migration engine allows the system to migrate pages from anywhere in the system to the GPU's memory for efficient processing. This improved memory handling results in significantly improved algorithm efficiency.

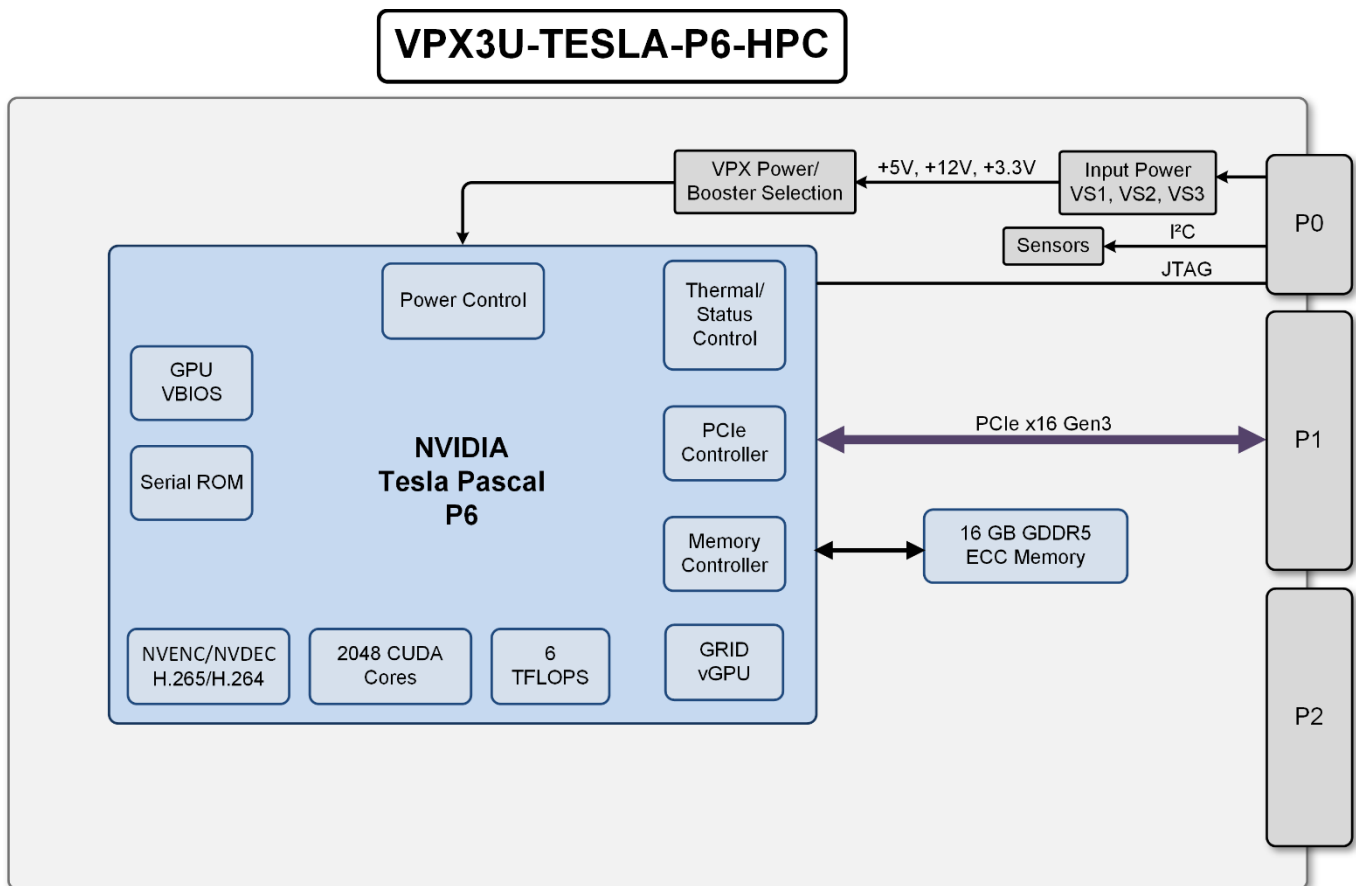

ORDERING CODES FOR VPX3U-TESLA-P6-HPC

Part Number	Description
111623-FD00*VPX3v10	3UVPX, Air Cooled 1", NVIDIA Tesla Pascal P6, 6 TFLOPS, 16GB GDDR5 ECC, 2048 CUDA Cores, x16 PCIe Gen3, I-Temp (-40C to +65C System Dependent)
111633-FD00*VPX3v10	3UVPX, Conduction Cooled 1", NVIDIA Tesla Pascal P6, 6 TFLOPS, 16GB GDDR5 ECC, 2048 CUDA Cores, x16 PCIe Gen3, I-Temp (-40C to +65C System Dependent)

* Contact Sales for full part number definition.

Options can include: Conformal Coating, Modified Power Cap, PCIe configuration, other

MANUFACTURING AND QUALITY ASSURANCE

WOLF designs modules to pass the following environmental standards:

- MIL-STD-810 (United States Military Standard for Environmental Engineering Considerations and Laboratory Tests)
- MIL-HDBK-217 (Reliability Prediction of Electronic Equipment)
- RTCA DO-160 (Environmental Conditions and Test Procedures for Airborne Equipment) on request

WOLF complies with the following quality management systems:

- ISO 9001:2015: Quality management systems (certified)
- SAE AS5553: Counterfeit Electronic Parts; Avoidance, Detection, Mitigation, and Disposition (compliant)
- SAE AS9100D: Quality Management System - Requirements for Aviation, Space and Defense Organizations (preparing for certification in 2019)

Boards are manufactured to meet the following standards:

- IPC-A-610 CLASS 3 (Acceptability of Electronic Assemblies)
- IPC 6012 CLASS 3 (Qualification and Performance Specification for Rigid Printed Boards, Class 3 for High Reliability Electronic Products)
- IPC J-STD-001 (Requirements for Soldered Electrical and Electronic Assemblies)

Caveat: integrated third party MXM modules may not meet the same standards as WOLF manufactured modules.

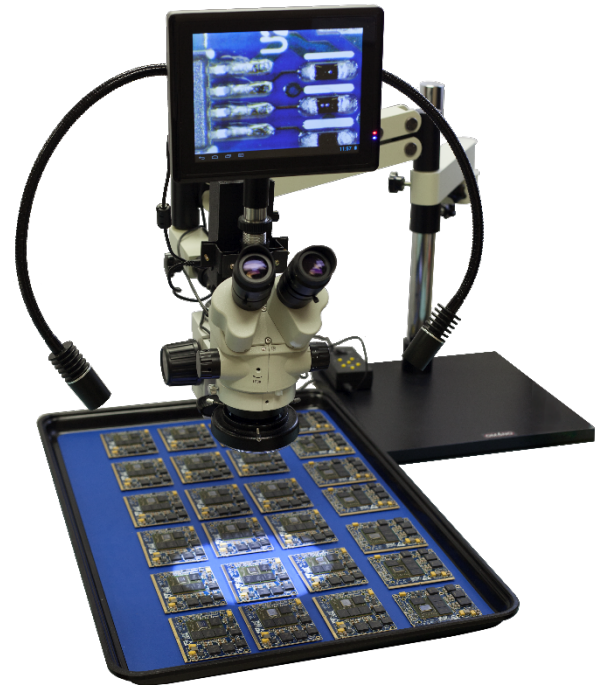

WOLF- 1116 VPX Module