

HD-SDI Frame Grabber with 325 GFLOPS Tegra K1 CUDA Processing

KEY FEATURES

- NVIDIA® Tegra® K1 APU for image processing
- WOLF Frame Grabber eXtreme (FGX) embedded FPGA capture engine
- HD-SDI input
- HD-SDI, HDMI or encoded H.264 TS output
- Advanced power management (tunable as low as 10 watts)

ADDITIONAL FEATURES

- NVIDIA Tegra K1 Embedded APU:
 - 5 ARM processor cores
 - Kepler 192 CUDA core GPGPU
 - 4 or 8 GB DDR3L memory
 - 64 GB Embedded Flash
- 2× HD-SDI input (SMPTE-292M)
- 1× HD-SDI output (SMPTE-292M); Optionally can be mirrored to a second output
- H.264 output over Ethernet or PCIe
- 1× HDMI output
- 1× USB 2.0 interface (480Mbps)
- 2× UART interfaces
- 1× 10/100/1000 Ethernet up to USB 2.0 speeds
- Embedded Linux environment

SPECIFICATIONS

- Manufactured in North America with full component traceability
- Component derating meets or exceeds NASA and Rome Labs specifications for reliability
- ENIG PCB surface plating
- Conformal coating options available (e.g., Parylene, Humiseal, others on request)
- MXC form factor (85x70 mm)
- High level of ruggedization:
 - Operating temperature: -40° to +85°C
 - Vibration (sine wave): 10G peak, 5 - 2000Hz
 - Shock: 30G peak for air-cooled, 40G peak for conduction-cooled

OVERVIEW

WOLF's MXC-FGX-TK1 is an image capture and processing module for aerospace and defense. It includes both an NVIDIA Tegra K1 APU and WOLF's Frame Grabber eXtreme (FGX). The FGX can capture two HD-SDI inputs. The video data can be routed to the Tegra K1 for processing and the processed data can be output as HD-SDI, HDMI or an encoded H.264 transport stream.

This module is designed for use as an ancillary processor module, for integration onto VPX carriers or COM Express baseboards, or operating as a stand-alone board.

The MXC-FGX-TK1 is designed to operate reliably in harsh environments while performing precision-intensive operations, such as image processing, video stabilization, filtering, terrain analytics, 3D visualization of geospatial data, object recognition, and tracking.

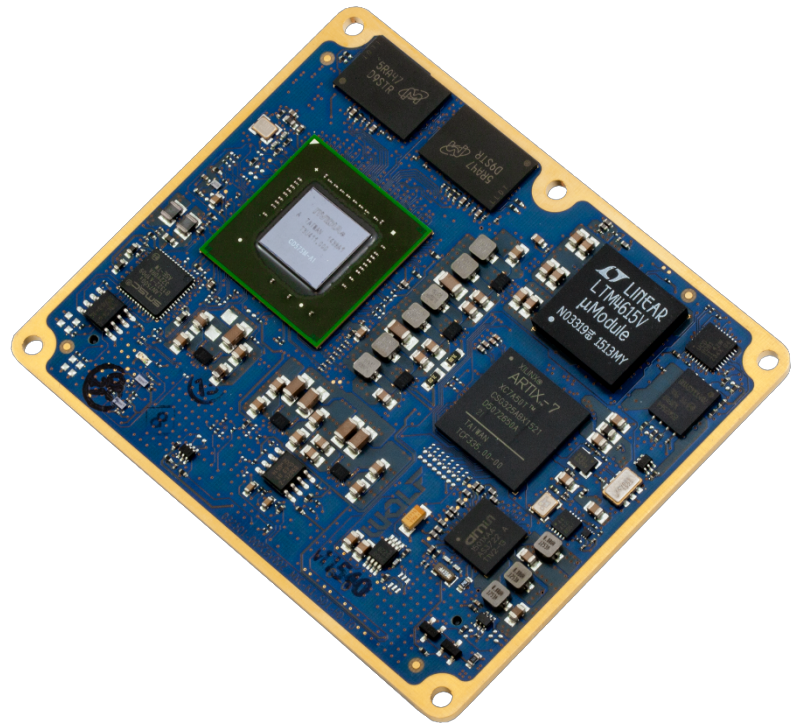

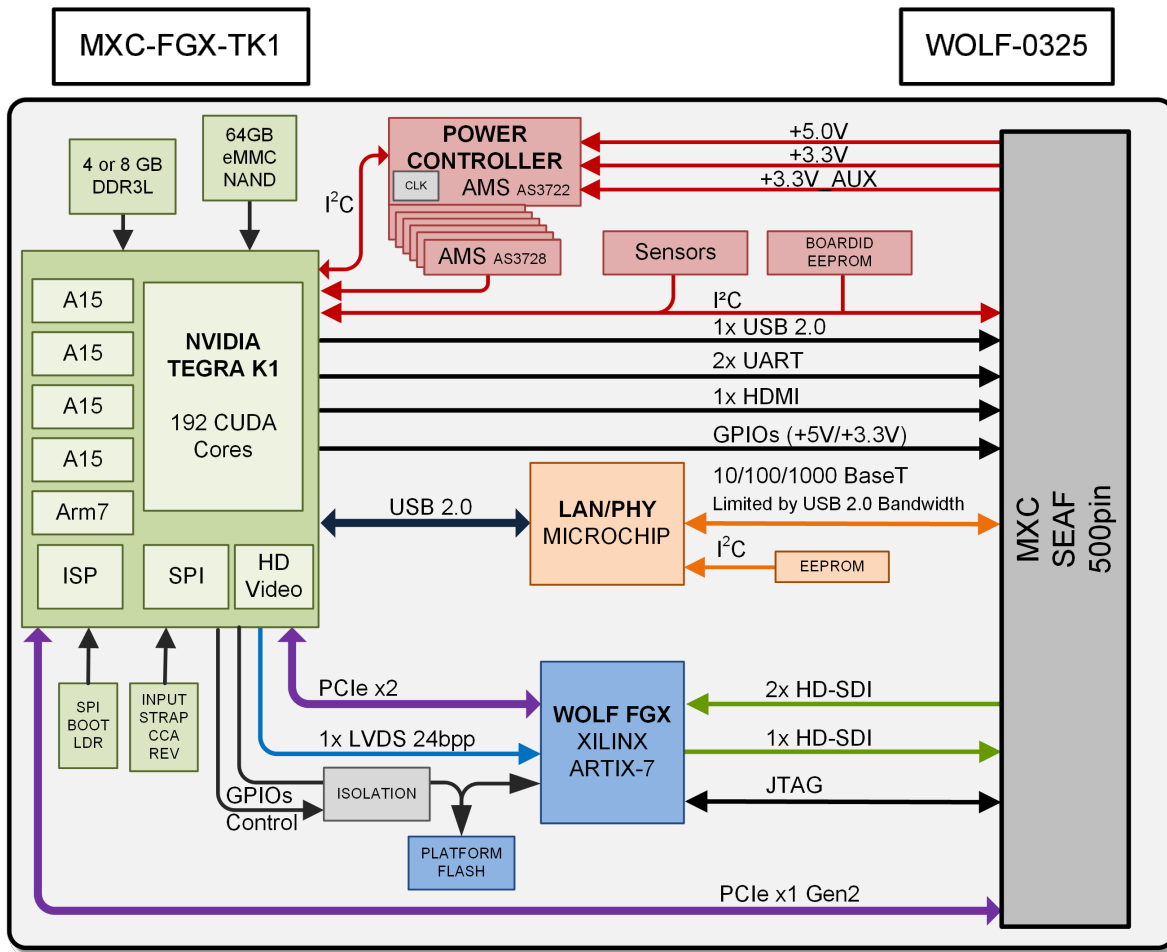

MANUFACTURING AND QUALITY ASSURANCE

WOLF stress tests to MIL-STD-810 (United States Military Standard for Environmental Engineering Considerations and Laboratory Tests) and MIL-HDBK-217 (Reliability Prediction of Electronic Equipment); Alternately will stress test to RTCA DO-160 (Environmental Conditions and Test Procedures for Airborne Equipment) on request.

WOLF products meet the following quality standards:

- ISO 9001:2015 (Quality management systems)
- IPC-A-610 CLASS 3 (Acceptability of Electronic Assemblies)
- IPC 6012 CLASS 3 (Qualification and Performance Specification for Rigid Printed Boards, Class 3 for High Reliability Electronic Products)
- IPC J-STD-001 Certified (Requirements for Soldered Electrical and Electronic Assemblies)

Boards are manufactured to meet the following standards:

- SAE AS9100D (Quality Management System - Requirements for Aviation, Space and Defense Organizations)
- SAE AS5553 (Counterfeit Electronic Parts; Avoidance, Detection, Mitigation, and Disposition)

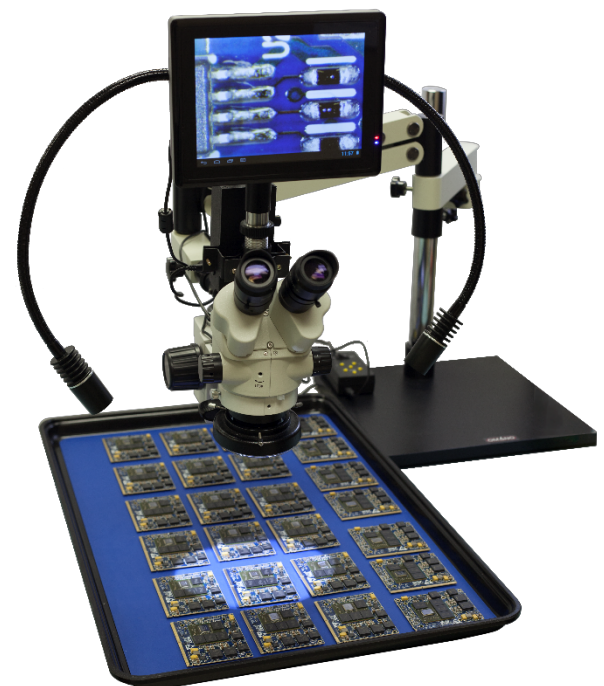

WOLF-0325 MXC Module