

SLC

Industrial Mini SATA III Module

PHANES-K Series

(JEDEC MO-300A)

Document No. : 100-xBMSM-PKCTC

Version No. : 02V0

Date : May, 2019

ISO 9001 : 2015 CERTIFIED

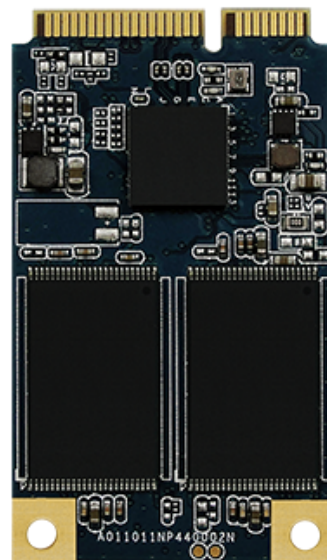

Product Features

■ Flash IC

- TOSHIBA NAND Flash IC.
- Single-Level Cell (SLC) management

■ Compatibility

- SATA Revision 3.2
- SATA 1.5Gb/s; SATA 3Gb/s & SATA 6Gb/s data transfer rate.
- ATA-8 ACS4 command set

■ Additional Capabilities

- S.M.A.R.T.*¹ (Self-Monitoring, Analysis and Reporting Technology) feature set support.
- Thermal Monitor for SSD's temperature.
- Native Command Queuing (NCQ) support.
- TRIM maintenance command support.
- Both Static & Dynamic wear-leveling algorithm
- Hardware Low Density Parity Check Code, LDPC support.

■ Mechanical

- JEDEC MO-300A full size Solid State Drive
- 52 pos. Edge Connector, PCI Express (PCIe) mini
- Dimension: 50.8 mm x 29.85 mm.
- Weight: 8.00 g / 0.28 oz.

■ Power Operating Voltage +3.3V±5%

- Read Mode: 1,650.0 mW (max.)
- Write Mode: 1,730.0 mW (max.)
- Idle Mode: 325.0 mW (max.)

■ Performance (Maximum value) *²

- Sequential Read: 510.0 MB/sec. (max.)
- Sequential Write: 305.0 MB/sec. (max.)

■ Capacity

- 8GB, 16GB and 32GB.

■ Reliability

- **TBW:** Up to 325 TBW at 32GB Capacity.
(Client workload by JESD-219A)
- **MTBF:** > 3,000,000 hours.
- **ECC:** Designed with hardware LDPC ECC engine with hard-decision and soft-decision decoding.
- **Temperature:** (Operating)
Standard Grade: 0°C ~ +70°C
Industrial Grade: -40°C ~ +85°C
- **Vibration:** 80 Hz to 2000 Hz, 20G, 3 axes.
- **Shock:** 0.5ms, 1500 G, 3 axes

■ Certifications and Declarations

- **Certifications:** CE & FCC
- **Declarations:** RoHS & REACH

Remarks:

1. Support official S.M.A.R.T. Utility.
2. Sequential performance is based on CrystalDiskMark 5.1.2 with file size 1000MB

Order Information

I. Part Number List

◆ APRO SLC Industrial Mini SATA III Module (mSATA) PHANES-K Series

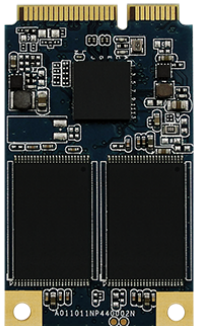
Product Picture	Grade	Standard grade (0°C ~ 70°C)	Industrial Grade (-40°C ~ +85°C)
	8GB	SBMSM008G-PKCTC-(W/T/WT)	WBMSM008G-PKITI-(W/T/WT)C
	16GB	SBMSM016G-PKCTC-(W/T/WT)	WBMSM016G-PKITI-(W/T/WT)C
	32GB	SBMSM032G-PKCTC-(W/T/WT)	WBMSM032G-PKITI-(W/T/WT)C

II. Part Number Decoder:

X1 X2 X3 X4 X5 X6 X7 X8 X9 — **X11 X12 X13 X14 X15** — **X17 X18**

X1 : Grade

S: Standard Grade – operating temp. 0° C ~ 70 ° C

W: Industrial Grade- operating temp. -40° C ~ +85 ° C

X2 : The material of case

B : Bare PCBA w/o Casing

X3 X4 X5 : Product category

MSM : mini SATA III Module

X6 X7 X8 X9 : Capacity

008G: 8GB

016G: 16GB

032G: 32GB

X11 : Controller

P : PHANES Series

X12 : Controller version

A, B, C.....

X13 : Controller Grade

C : Commercial grade

I : Industrial grade

X14 : Flash IC

T : Toshiba NAND Flash IC

X15 : Flash IC grade / Type

C : Commercial grade

I : Industrial grade

X17 X18 : Reserved for specific requirement

Blank : Standard product w/o thermal sensor and conformal-coating

W : Write Protection Switch (optional)

T : Thermal Sensor (optional)

WT : Write Protection Switch + Thermal Sensor (optional)

C : Conformal coating (optional)

Revision History

Revision	Description	Date
1.0	Initial release.	2018/11/08
1.1	Updated Version	2018/11/28
2.0	Updated document form	2019/05/21

Contents

Product Features	- 2 -
Order Information	- 3 -
I. Part Number List	- 3 -
II. Part Number Decoder:	- 3 -
Revision History	- 4 -
Contents	- 5 -
1. Introduction	- 6 -
1.1. Scope	- 7 -
1.2. Flash Management Technology - Static & Dynamic Wear Leveling	- 7 -
1.3. Bad Block Management	- 7 -
1.4. Mean Time Between Failure (MTBF)	- 7 -
1.4.1. Definition	- 7 -
1.4.2. Obtaining MTBF	- 8 -
1.4.3. Definitions	- 9 -
2. Product Specifications	- 11 -
2.1. System Environmental Specifications	- 11 -
2.2. System Power Requirements	- 11 -
2.3. System Performance	- 11 -
2.4. System Reliability	- 12 -
2.5. Physical Specifications	- 12 -
2.6. Conformal coating	- 13 -
3. Interface Description	- 14 -
3.1. SLC Industrial Mini SATA III Module (mSATA) interface	- 14 -
3.2. Pin Assignments	- 15 -
Appendix A: Limited Warranty	- 16 -

1. Introduction

APRO SLC Industrial Mini SATA III Module (mSATA) PHANES-K Series provides high capacity flash memory Solid State Drive (SSD) that electrically complies with SATA Revision 3.2 standard. APRO SLC Industrial Mini SATA III Module (mSATA) PHANES-K Series support SATA 1.5Gb/s; SATA 3Gb/s & SATA 6Gb/s data transfer rate with high performance. It is designed with mSATA form factor by JEDEC MO-300A standard, and the available disk capacities are 8GB, 16GB and 32GB. The operating temperature grade is optional for Standard grade 0°C ~ 70°C and Industrial Grade with conformal coating supports -40°C ~ +85°C.

APRO SLC Industrial Mini SATA III Module (mSATA) PHANES-K Series provide the high random speed for heavy-loading embedded or server operations with space constraints for host computing systems; the performance of sequential read is up to 510.0 MB/sec., and sequential write is up to 305.0 MB/sec.

APRO SLC Industrial Mini SATA III Module (mSATA) PHANES-K Series provides a high level interface to the host computer. This interface allows a host computer to issue commands to the APRO SLC Industrial Mini SATA III Module (mSATA) PHANES-K Series to read or write blocks of memory. A powerful hardware design is architecture multiplied LDPC (Low Density Parity Check) for Error Correcting Coding (ECC). APRO SLC Industrial Mini SATA III Module (mSATA) PHANES-K Series intelligent controller manages interface protocols, data storage and retrieval as well as ECC, bad block management and diagnostics, power management and clock control.

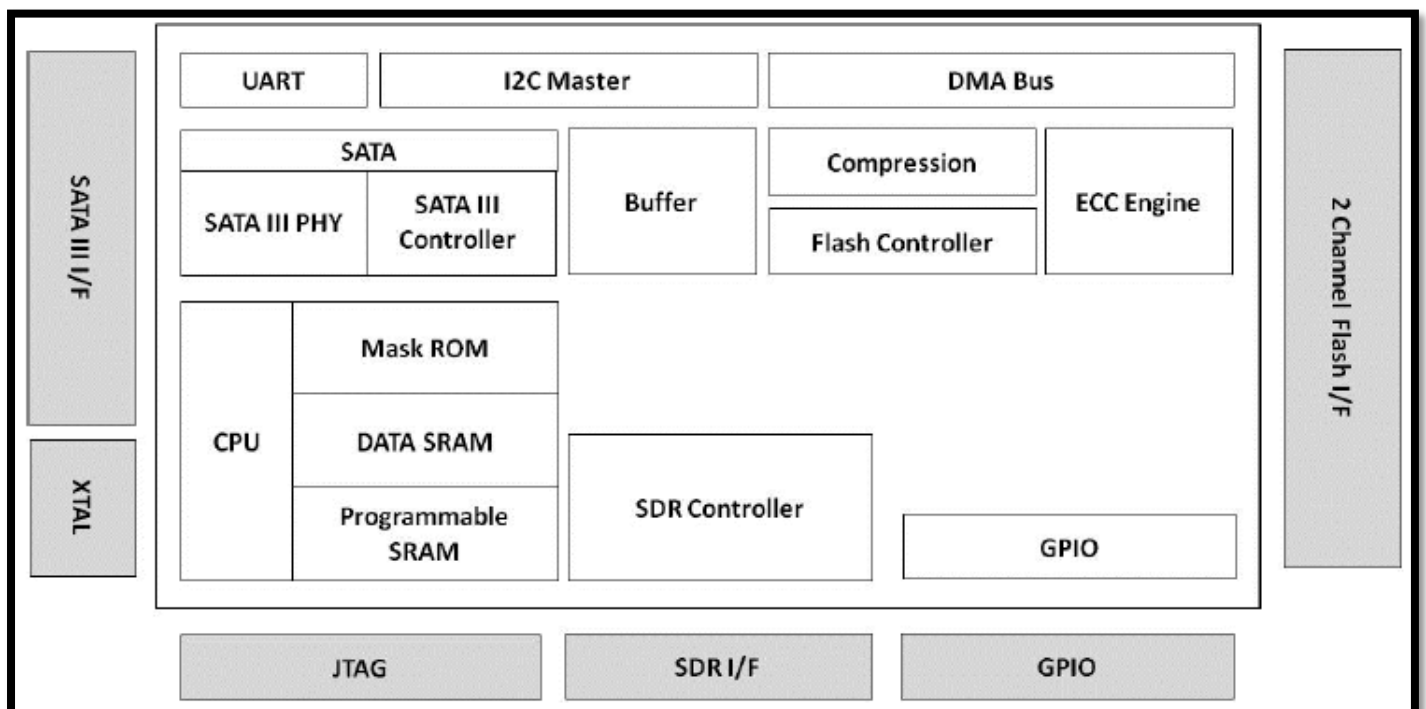

Figure 1: APRO SLC Industrial Mini SATA III Module (mSATA) PHANES-K Series block diagram

1.1. Scope

This document describes features, specifications and installation guide of APRO SLC Industrial Mini SATA III Module (mSATA) PHANES-K Series. In the appendix, there provides order information, warranty policy, RMA/DOA procedure for the most convenient reference.

1.2. Flash Management Technology - Static & Dynamic Wear Leveling

NAND flash devices can only undergo a limited number of program/erase cycles, and in most cases, the flash media are not used evenly. If some areas get updated more frequently than others, the lifetime of the device would be reduced significantly. Thus, Wear Leveling is applied to extend the lifespan of NAND Flash by evenly distributing write and erase cycles across the media.

APRO SLC Industrial Mini SATA III Module (mSATA) PHANES-K Series provides advanced Wear Leveling algorithm, which can efficiently spread out the flash usage through the whole flash media area. Moreover, by implementing both dynamic and static Wear Leveling algorithms, the life expectancy of the NAND flash is greatly improved.

1.3. Bad Block Management

➤ Early Bad Block

The fault block generated during the manufacturing process of NAND Flash is called Early Bad Block.

➤ Later Bad Block

In the process of use, as the number of operations of writing and erasing increases, a fault block is gradually generated, which is called a Later Bad Block.

Bad block management is a management mechanism for a bad block to be detected by the control IC and mark bad blocks in the NAND Flash and improve the reliability of data access. The bad block management mechanism of the control IC will establish a **Bad Block Table** when the NAND Flash is started for the first time, and will also record the errors found in the process of use in the bad block table, and data is ported to new valid blocks to avoid data loss.

In order to detect the initial bad blocks to handle run time bad blocks, APRO SLC Industrial Mini SATA III Module (mSATA) PHANES-K Series provides the **Bad Block Management** scheme. It remaps a bad block to one of the reserved blocks so that the data contained in one bad block is not lost and new data writes on a bad block is avoided.

1.4. Mean Time Between Failure (MTBF)

1.4.1. Definition

MTBF (Mean time between failures) is defined as failure or maintenance required for the average time including failure detection and maintenance for the device. For a simple and maintainable unit, $MTBF = MTTF + MTTR$.

MTTF (mean time to failure) is defined as the expectation of random variables for time to failure.

MTTR (mean time to restoration) is the expectation of random variables of time required for restoration which includes the time required for confirmation that a failure occurred, as well as the time required for maintenance.

1.4.2. Obtaining MTBF

There are two methods for obtaining MTBF:

A. MTBF software estimation method: by calculating all the MTBF data of all the components included in the bill of material, and the data of the completed products including actual parameters of voltage and electrical current using analysis software, the MTBF of the completed product is estimated.

B. MTBF sample test method: by determining a certain number of samples and a fixed time for testing, using a Arrhenius Model and Coffin-Manson Model to obtain parameters, and then using the formula with the parameters, the longevity and in so the reliability is proved.

Arrhenius Model: $Af = e\{ (1/k \times Ea (1/273+Tmax - 1/273+Ttest))\}$

Coffin-Manson Model: $Af = (\Delta Ttest/\Delta Tuse)m$

➤ **APRO uses the A method to Estimate MTBF**

MTBF is actually obtained by calculation which is just an estimation of future occurrences. The main reason to use the first method is that the data contains the analysis by all the parameters of components and actual parameters of voltage and electrical current of finished products, which is considered adequate and objective.

➤ **Interpretation of MTBF Analysis**

APRO estimates MTBF using a prediction methodology based on reliability data for the individual components in APRO products. The predicted MTBF based on Parts stress analysis Method of Telcordia Special Report SR-332, for components failure rates. Component data comes from several sources: device life tests, failure analysis of earlier equipment, device physics, and field returns.

The Telcordia model is based on the Telcordia document, Reliability Prediction Procedure for Electronic Equipment, Technical Reference SR-332. This standard basically modified the component models in MIL-HDBK-217 to better reflect the failure rates that AT&T Bell Lab equipment was experiencing in the field and was originally developed by AT&T Bell Lab as the Bellcore model.

This model supports different failure rate calculation methods in order to support the taking into account of stress, burn-in, laboratory, or field data. A Parts Count or Parts Stress analysis is included in Telcordia performance. Relx supports Telcordia Issues 1 and 2 and also Bellcore Issues 4, 5, and 6. Telcordia Issue 2, released in September 2006, are supported by Relx and Telcordia Issue 1, released in May 2001, is replaced with Relx. Refer to Telcordia Issue 2 Fields for information about the fields in Relx Reliability Studio specific to Telcordia Issue 2.

➤ **Purpose of the analyses**

The purpose of these analyses is to obtain early estimation of device reliability during engineering and customer validation stages. The prediction results will expose the reliability of whole assembly, viewed as a set of serially connected electronic components. Rating of the assembly electronic components will show the ratio between actual critical elements parameters and their specification limits. The purpose of component rating is to improve a product's inherent design reliability, increase its number of operating times, and to reduce warranty costs and to achieve a more robust design.

1.4.3. Definitions

Term	Definition
Failure	The event, or inoperable state, in which any item or part of an item does not, or would not, perform as previously specified.
Failure rate	The total number of failures within an item population, divided by the total number of life units expended by that population, during a particular measurement interval under stated condition.
FIT	Failures In Time: the number of failures in 1 billion hours.
PPM	Part per million: the number of failures in 1 million hours.
Mean Time Between Failures (MTBF)	A basic measure of reliability for repairable items: The mean number of life units during which all parts of the item perform within their specified limits, during a particular measurement interval under stated conditions..
GB	Ground, Fixed, Controlled: Nearly zero environmental stress with optimum engineering operation and maintenance. Typical applications are central office, environmentally controlled vaults, environmentally controlled remote shelters, and environmentally controlled customer premise area.
GF	Ground, Fixed, Uncontrolled: Some environmental stress with limited maintenance. Typical applications are manholes, poles, remote terminals, and customer premise areas subject to shock, vibration, temperature, or atmospheric variations.

➤ Software & Database

Analysis Software & Analysis Method

Software Name : Relex Reliability Studio 2008

Software Version : Relex Studio 2008

Analysis Method

The prediction method used was Telcordia SR-332, Issue 2,

Parts Count

Failure rate (λ) = 10^9 hours (FITs)

MTBF = $1/\lambda$

$\lambda_{SSi} = \lambda_{Gi} TT_{Qi} TT_{Si} TT_{Ti}$

Where λ_{Gi} : Generic steady-state failure rate for device i

TT_{Qi} : Quality factor for device i

TT_{Si} : Stress factor for device i

TT_{Ti} : Temperature factor for device i

➤ Calculation Parameter

Operation Temperature : 25°C

Environment : Ground Benign, Controlled

Operation Stress : 50% (Voltage, Current, Power)

Method : Method I, Case 3

Products are advertised with MTBF up to 1 million hours in the market. Take one million hours as an example, the product's estimated life is 114 years. However, the current rapid progress of technology, advancement of flash storage device's manufacturing process research and development, and the supply period of former flash IC manufacturing processes are crucial to the actual life expectancy of flash products. In short, the MTBF of flash storage is for reference only. Good customer service and technical support provided by manufacturers is the most significant issue regarding to the life-span of products.

Remark:

All the details of testing and data are for reference only and do not imply any products performance as a result. MTBF is only an estimated date and is depends on both hardware and software. User shall not assume that all the products have the same MTBF as APRO estimates.

2. Product Specifications

For all the following specifications, values are defined at ambient temperature and nominal supply voltage unless otherwise stated.

2.1. System Environmental Specifications

Table 1: Environmental Specification

APRO SLC Industrial Mini SATA III Module (mSATA)		Standard Grade	Industrial Grade
PHANES-K Series		SBMSMxxxG-PKCTC	WBMSMxxxG-PKITI
Temperature	Operating:	0°C ~ +70°C	-40°C ~ +85°C
	Non-operating:	-20°C ~ +80°C	-50°C ~ +95°C
Humidity	Operating & Non-operating:	10% ~ 95% non-condensing	
Vibration	Frequency/Acceleration:	80 Hz to 2K Hz, 20G, 3 axes	
Shock	Operating & Non-operating:	0.5ms, 1500 G, 3 axes	
Electrostatic Discharge (ESD)	Temperature:	24°C	
	Relative Humidity:	49% (RH)	
	+/-4KV:	Device functions are affected, but EUT will be back to its normal or operational state automatically.	

2.2. System Power Requirements

Table 2: Power Requirement

APRO SLC Industrial Mini SATA III Module (mSATA) PHANES-K Series		
DC Input Voltage (VCC)		+3.3V±5%
Maximum average value	Reading Mode :	1,650.0 mW (max.)
	Writing Mode :	1,730.0 mW (max.)
	Idle Mode :	325.0 mW (max.)

2.3. System Performance

Table 3: System Performances

Data Transfer Mode supporting		Serial ATA Gen-III (6.0Gb/s = 768MB/s)		
Maximum Performance	Capacity	8GB	16GB	32GB
	Sequential Read (MB/s)	320.0	540.0	510.0
	Sequential Write (MB/s)	70.0	150.0	305.0

Note:

- The performance was measured using CrystalDiskMark v5.0x64 with SATA 6Gbps host.
- Samples were built using Toshiba 15nm Toggle SLC NAND.
- Performance may differ according to flash configuration, SDR configuration, and platform.
- The table above is for reference only. The criteria for MP (mass production) and for accepting goods shall be discussed based on different flash configuration.

2.4. System Reliability

Table 4: System Reliability

Wear-leveling Algorithms		Static and Dynamic wear-leveling algorithms
Bad Block Management		Supportive
ECC Technology		Hardware design LDPC (Low Density Parity Check)
Erase counts		NAND SLC Flash Cell Level : 60K P/E Cycles
TBW (Tera Bytes Written)		
Capacity	8GB	74.0
	16GB	153.0
	32GB	325.0

Note:

- Samples were built using Toshiba SLC NAND flash.
- Client workload by JESD-219A
- The endurance of SSD could be estimated based on user behavior, NAND endurance cycles, and write amplification factor.
It is not guaranteed by flash vendor.

2.5. Physical Specifications

Refer to Table 5 and see Figure 2 for APRO SLC Industrial Mini SATA III Module (mSATA) PHANES-K Series physical specifications and dimensions.

Table 5: Physical Specifications of APRO SLC Industrial Mini SATA III Module (mSATA) PHANES-K Series

Length:	50.8 mm
Width:	29.85 mm
Weight:	8.00 g / 0.28 oz.

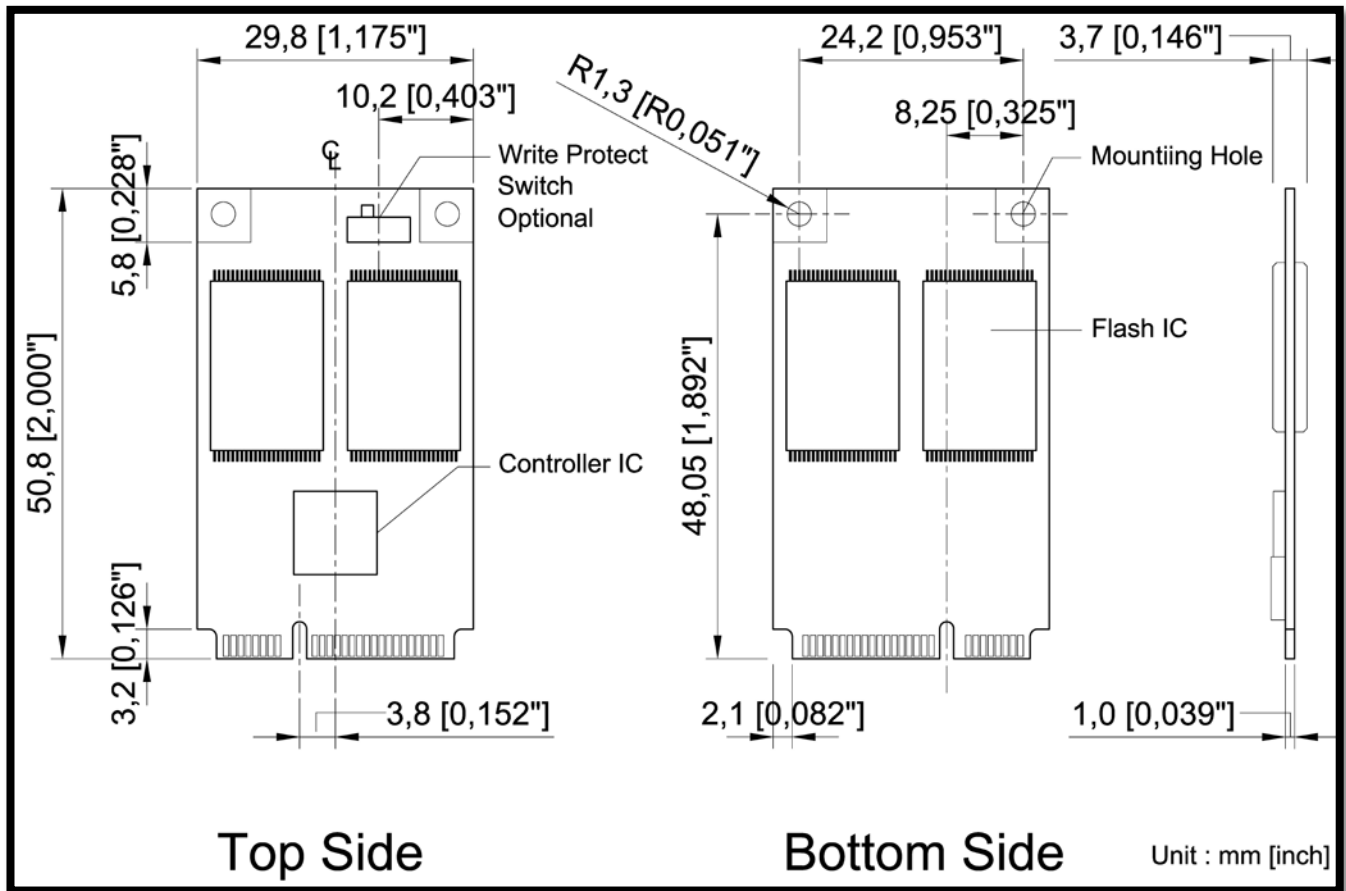

Figure 2: APRO Mini SATA III Module (JEDEC MO-300A) Dimension

2.6. Conformal coating

Conformal coating is a protective, dielectric coating designed to conform to the surface of an assembled printed circuit board. Commonly used conformal coatings include silicone, acrylic, urethane and epoxy. APRO applies only silicone on APRO storage products upon requested especially by customers. The type of silicone coating features good thermal shock resistance due to flexibility. It is also easy to apply and repair.

Conformal coating offers protection of circuitry from moisture, fungus, dust and corrosion caused by extreme environments. It also prevents damage from those Flash storages handling during construction, installation and use, and reduces mechanical stress on components and protects from thermal shock. The greatest advantage of conformal coating is to allow greater component density due to increased dielectric strength between conductors.

APRO use MIL-I-46058C silicon conformal coating

3. Interface Description

3.1. Mini SATA III Module (mSATA) interface

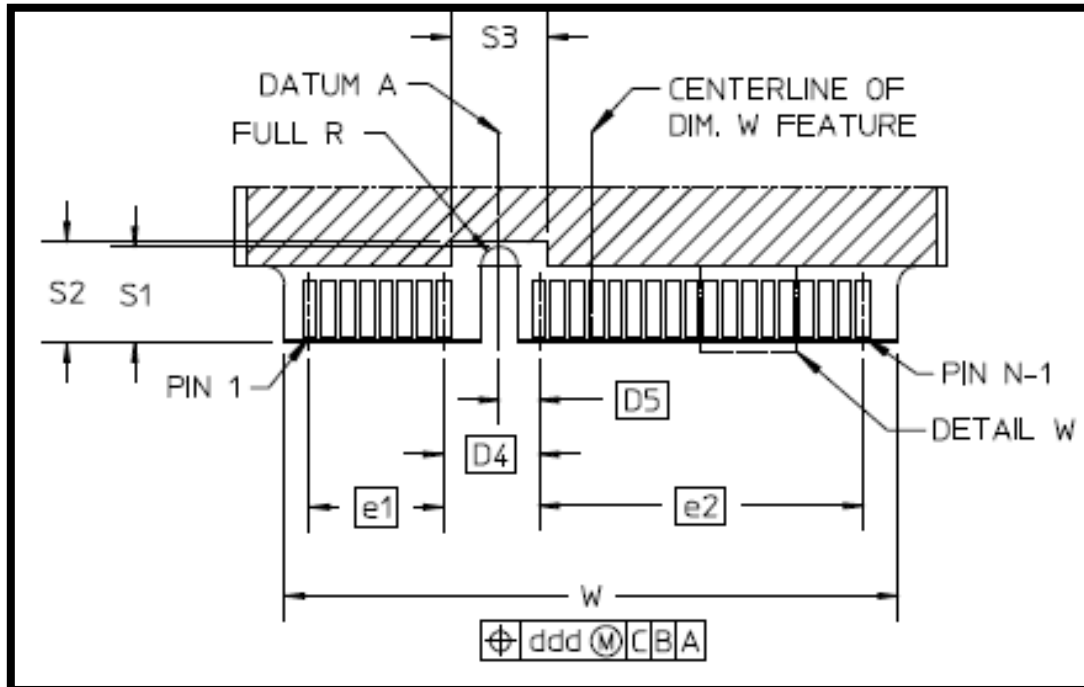

Figure 3: The connectors of Signal Segment and Power Segment

3.2. Pin Assignments

APRO SLC Industrial Mini SATA III Module (mSATA) PHANES-K Series operates with standard SATA pin-out. The pin assignments are listed in below table 6.

Table 6 - Pin Assignments

Signal Name	Pin #	Pin #	Signal Name
NC	1	2	+ 3.3V
NC	3	4	DGND
NC	5	6	NC
NC	7	8	NC
DGND	9	10	NC
NC	11	12	NC
NC	13	14	NC
DGND	15	16	NC
NC	17	18	DGND
NC	19	20	NC
SATA GND	21	22	NC
TX+	23	24	+ 3.3V
TX-	25	26	SATA GND
SATA GND	27	28	NC
SATA GND	29	30	NC
RX-	31	32	NC
RX+	33	34	DGND
SATA GND	35	36	NC
SATA GND	37	38	NC
+ 3.3V	39	40	DGND
+ 3.3V	41	42	NC
NC	43	44	DEVSLP
NC	45	46	NC
NC	47	48	NC
DAS	49	50	DGND
GND	51	52	+ 3.3V

Appendix A: Limited Warranty

APRO warrants your SLC Industrial Mini SATA III Module (mSATA) PHANES-K Series against defects in material and workmanship for the life of the drive. The warranty is void in the case of misuse, accident, alteration, improper installation, misapplication or the result of unauthorized service or repair. The implied warranties of merchantability and fitness for a particular purpose, and all other warranties, expressed or implied, except as set forth in this warranty, shall not apply to the products delivered. In no event shall APRO be liable for any lost profits, lost savings or other incidental or consequential damages arising out of the use of, or inability to use, this product.

BEFORE RETURNING PRODUCT, A RETURN MATERIAL AUTHORIZATION (RMA) MUST BE OBTAINED FROM APRO.

Product shall be returned to APRO with shipping prepaid. If the product fails to conform based on customers' purchasing orders, APRO will reimburse customers for the transportation charges incurred.

WARRANTY PERIOD:

- **SLC STD. Grade 3 years / Within 60K Erasing Counts**
- **SLC IND. Grade 5 years / Within 60K Erasing Counts**

This document is for information use only and is **subject to change without prior notice**. APRO Co., Ltd. assumes no responsibility for any errors that may appear in this document, nor for incidental or consequential damages resulting from the furnishing, performance or use of this material. No part of this document may be reproduced, transmitted, transcribed, stored in a retrievable manner or translated into any language or computer language, in any form or by any means, electronic, mechanical, magnetic, optical, chemical, manual or otherwise, without the prior written consent of an officer of APRO Co., Ltd.

All parts of the APRO documentation are protected by copyright law and all rights are reserved.

APRO and the APRO logo are registered trademarks of APRO Co., Ltd.

Product names mentioned herein are for identification purposes only and may be trademarks and/or registered trademarks of their respective companies.

© 2018 APRO Corporation. All rights reserved