

SLC

Industrial 2.5" SATA III SSD

HERMES-HR Series

Support Power interrupts data protection technology
by Tantalum Capacitors.



Document No. : 100-xR2SR-JHTS

Version No. : 02V0

Date : June, 2019

ISO 9001 : 2015 CERTIFIED



Product Features

■ Flash IC

- TOSHIBA NAND Flash IC.
- Single-Level Cell (SLC) management

■ Compatibility

- Compliant with SATA Revision 3.1
- SATA 1.5Gb/s; SATA 3Gb/s & SATA 6Gb/s Interface compatible.
- ATA-8 command set

■ Additional Capabilities

- S.M.A.R.T.*¹ (Self-Monitoring, Analysis and Reporting Technology) feature set support.
- Native Command Queuing (NCQ) support.
- TRIM maintenance command support.
- Support Static wear-leveling algorithm
- Designed with a DRAM buffer which is support high transfer rate
- Power interrupts data protection technology by Tantalum Capacitors.
- Support Bad Block Management

■ Mechanical

- Standard 2.5" SATA Flash Disk form-factor (7mm)
- SATA 7-pin (data) + 15-pin (power connector) SATA Interface
- Dimension: 100.0mm x 70.0mm x 8.8mm.
- Weight: 75.0 g / 2.64 oz.

■ Power Operating Voltage 5V(+/-) 5%

- Read Mode: 415.0 mA. (max.)
- Write Mode: 630.0 mA. (max.)
- Idle Mode: 193.0 mA. (max.)

■ Performance (Maximum value) *²

- Sequential Read: 512.7 MB/sec. (max.)
- Sequential Write: 354.6 MB/sec. (max.)
- 4KB Random Read IOPS (QD32): 11.3K
- 4KB Random Write IOPS (QD32): 5.5K
- 4KB Random Read access time: 0.11ms
- 4KB Random Write access time: 0.36ms

■ Capacity

- 8GB, 16GB, 32GB, 64GB, 128GB and 256GB

■ Reliability

- **TBW:** Up to 13,824 TBW at 256GB Capacity. (Test by sequential write)
- **MTBF:** > 3,000,000 hours
- **ECC:** Powerful ECC capable of correcting errors up to 66-bit per 1KB.
- **Temperature:** (Operating)
Standard Grade: 0°C ~ +70°C
Industrial. Grade: -40°C ~ +85°C
- **Vibration:** 70 Hz to 2000 Hz, 20G, 3 axes.
- **Shock:** 0.5ms, 1500 G, 3 axes.

■ Certifications and Declarations

- **Certifications:** CE & FCC
- **Declarations:** RoHS & REACH

Remarks:

1. Support official S.M.A.R.T. Utility.
2. Sequential performance is based on CrystalDiskMark 5.1.2 with file size 1000MB

Order Information

I. Part Number List

◆ APRO SLC 2.5" SATA III SSD HERMES-HR Series

| Product Picture | Grade | Standard grade (0°C ~ 70°C) | Industrial Grade (-40°C ~ +85°C) |
|---|-------|-----------------------------|------------------------------------|
|  | 8GB | SR2SR008G-JHCTC | WR2SR008G-JHITI |
| | 16GB | SR2SR016G-JHCTC | WR2SR016G-JHITI |
| | 32GB | SR2SR032G-JHCTC | WR2SR032G-JHITI |
| | 64GB | SR2SR064G-JHCTC | WR2SR064G-JHITI |
| | 128GB | SR2SR128G-JHCTC | WR2SR128G-JHITI |
| | 256GB | SR2SR256G-JHCTC | WR2SR256G-JHITI |

II. Part Number Decoder:

X1 X2 X3 X4 X5 X6 X7 X8 X9 — **X11 X12 X13 X14 X15** — **X17**

X1 : Grade

S: Standard Grade – operating temp. 0° C ~ 70 ° C

W: Industrial Grade – operating temp. -40° C ~ +85 ° C

X2 : The material of case

R : Rugged Metal

X3 X4 X5 : Product category

2SR :

2.5" SATA SSD w/DRAM cache

X6 X7 X8 X9 : Capacity

| | | | |
|--------------|------|--------------|-------|
| 008G: | 8GB | 064G: | 64GB |
| 016G: | 16GB | 128G: | 128GB |
| 032G: | 32GB | 256G | 256GB |

X11 : Controller

J : HERMES Series

X12 : Controller version

A, B, C.....

X13 : Controller Grade

C : Commercial grade

I : Industrial grade

X14 : Flash IC

T : Toshiba SLC-NAND Flash IC

X15 : Flash IC grade / Type

C : Commercial grade

I : Industrial grade

X17 : Reserved for specific requirement

C : Conformal-coating (optional)

Revision History

| Revision | Description | Date |
|----------|---|------------|
| 1.0 | Initial release | 2014/3/11 |
| 1.1 | Adding Tantalum Capacitors' Description | 2014/06/12 |
| 1.2 | Updated Version | 2018/11/28 |
| 2.0 | Updated Document Format | 2019/06/05 |

Contents

| | |
|--|--------|
| Product Features | - 2 - |
| Order Information | - 3 - |
| I. Part Number List | - 3 - |
| II. Part Number Decoder: | - 3 - |
| Revision History | - 4 - |
| Contents | - 5 - |
| 1. Introduction | - 6 - |
| 1.1. Scope | - 7 - |
| 1.2. Flash Management Technology – Static Wear Leveling | - 7 - |
| 1.3. Bad Block Management | - 7 - |
| 1.4. DRAM Buffer | - 7 - |
| 1.5. Power interrupts data protection Technology | - 8 - |
| 1.6. Mean Time Between Failure (MTBF) | - 8 - |
| 1.6.1. Definition | - 8 - |
| 1.6.2. Obtaining MTBF | - 8 - |
| 1.6.3. Definitions | - 9 - |
| 2. Product Specifications | - 11 - |
| 2.1. System Environmental Specifications | - 11 - |
| 2.2. System Power Requirements | - 11 - |
| 2.3. System Performance | - 11 - |
| 2.4. System Reliability | - 12 - |
| 2.5. Physical Specifications | - 12 - |
| 2.6. Conformal coating | - 14 - |
| 3. Interface Description | - 14 - |
| 3.1. 2.5" SATA III SSD interface | - 14 - |
| 3.2. Pin Assignments | - 15 - |
| Appendix A: Limited Warranty | - 16 - |

1. Introduction

APRO SLC Industrial 2.5" SATA III SSD HERMES-HR Series provides high capacity flash memory Solid State Drive (SSD) that electrically complies with Serial ATA 3.1 (SATA) standard and ATA-8 command set compatible. APRO SLC Industrial 2.5" SATA III SSD HERMES-HR Series support SATA 1.5Gb/s; SATA 3Gb/s & SATA 6Gb/s data transfer rate with high performance, and designed with a DRAM which is support the data buffer for SSD; The available disk capacities are 8GB, 16GB, 32GB, 64GB, 128GB and 256GB.

The operating temperature grade is optional for Standard grade 0°C ~ 70°C and Industrial grade supports -40°C ~ +85°C. The data transfer performance by sequential read is up to 512.7 MB/sec, and sequential write is up to 354.6 MB/sec. The 4K random Read IOPS up to 11.3K and the 4K random Write IOPS up to 5.5K.

APRO SLC Industrial 2.5" SATA III SSD HERMES-HR Series built-in DRAM products provide a high level interface to the host computer. This interface allows a host computer to issue commands to the 2.5" SATA III SSD to read or write blocks of memory. Each sector is protected by a powerful 40 bits per 1024 bytes error correction (ECC). APRO SLC Industrial 2.5" SATA III SSD HERMES-HR Series intelligent controller manages interface protocols, data storage and retrieval as well as ECC, defect handling and diagnostics, power management and clock control.

Figure 1 shows a block diagram of the APRO SLC Industrial 2.5" SATA III SSD HERMES-HR Series.

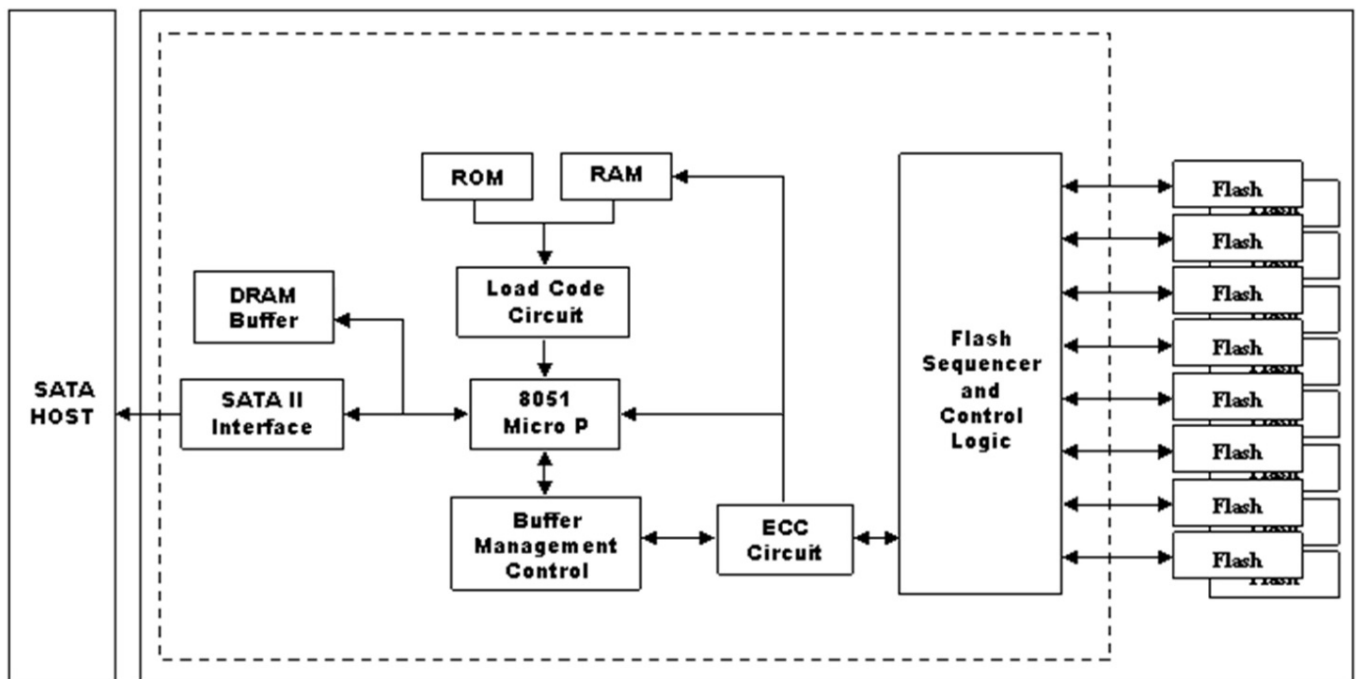

Figure 1: APRO SLC Industrial 2.5" SATA III SSD HERMES-HR Series block diagram

1.1. *Scope*

This document describes features, specifications and installation guide of APRO SLC Industrial 2.5" SATA III SSD HERMES-HR Series. In the appendix, there provides order information, warranty policy, RMA/DOA procedure for the most convenient reference.

1.2. *Flash Management Technology – Static Wear Leveling*

In order to gain the best management for flash memory, APRO SLC Industrial 2.5" SATA III SSD HERMES-HR Series supports Static Wear-leveling technology to manage the Flash system. The life of flash memory is limited; the management is to increase the life of the flash product.

A static wear-leveling algorithm evenly distributes data over an entire Flash cell array and searches for the least used physical blocks. The identified low cycled sectors are used to write the data to those locations. If blocks are empty, the write occurs normally. If blocks contain static data, it moves that data to a more heavily used location before it moves the newly written data. The static wear leveling maximizes effective endurance Flash array compared to no wear leveling or dynamic wear leveling.

1.3. *Bad Block Management*

➤ **Early Bad Block**

The fault block generated during the manufacturing process of NAND Flash is called Early Bad Block.

➤ **Later Bad Block**

In the process of use, as the number of operations of writing and erasing increases, a fault block is gradually generated, which is called a Later Bad Block.

Bad block management is a management mechanism for a bad block to be detected by the control IC and mark bad blocks in the NAND Flash and improve the reliability of data access. The bad block management mechanism of the control IC will establish a **Bad Block Table** when the NAND Flash is started for the first time, and will also record the errors found in the process of use in the bad block table, and data is ported to new valid blocks to avoid data loss.

In order to detect the initial bad blocks to handle run time bad blocks, APRO SLC Industrial 2.5" SATA III SSD HERMES-HR Series provides the **Bad Block Management** scheme. It remaps a bad block to one of the reserved blocks so that the data contained in one bad block is not lost and new data writes on a bad block is avoided.

1.4. *DRAM Buffer*

SSDs designed with a DRAM buffer which is support high transfer rate as a data buffer for the SSD; SSD with DRAM buffer is able to deliver excellent random data transfer speed.

- 8GB to 256GB Supports 2GBits DRAM Cache

1.5. Power interrupts data protection Technology

In the event of an unstable power supply, SSD loses power before it can finish programming process from host to flash, this may cause data being written to the incorrect block and further leads to data corruption.

Power interrupt data protection technology is applied with several tantalum capacitors to provide power buffering after host power interruption. The Data Protection Technology provides enough time for the SSD controller can write all DRAM buffer data to flash, all data will be protected and without data loss.

The ability of Power interrupt data protection technology is able to write 1.28MB of data within 60ms.

This ensures all data in the DRAM buffer can be successfully written into flash.

Traditionally, super capacitors were applied in most SSD products, the advantages of tantalum capacitors over super capacitors are:

➤ **Tantalum capacitors are electrolyte free.**

It is able to maintain its designed capacitance for several years when used within design limits.

➤ **Wide operating temperature range.**

Tantalum capacitors can operate from temperature range of -55C to +125C, which is very suitable for industrial and military usage.

➤ **Tantalum capacitors have an ultimate high volumetric efficiency (CV/cc).**

For example, a 50-microfarad tantalum capacitor can be equal and to properly replace a 500-microfarad aluminum capacitor.

1.6. Mean Time Between Failure (MTBF)

1.6.1. Definition

MTBF (Mean time between failures) is defined as failure or maintenance required for the average time including failure detection and maintenance for the device. For a simple and maintainable unit, $MTBF = MTTF + MTTR$.

MTTF (mean time to failure) is defined as the expectation of random variables for time to failure.

MTTR (mean time to restoration) is the expectation of random variables of time required for restoration which includes the time required for confirmation that a failure occurred, as well as the time required for maintenance.

1.6.2. Obtaining MTBF

There are two methods for obtaining MTBF:

A. MTBF software estimation method: by calculating all the MTBF data of all the components included in the bill of material, and the data of the completed products including actual parameters of voltage and electrical current using analysis software, the MTBF of the completed product is estimated.

B. MTBF sample test method: by determining a certain number of samples and a fixed time for testing, using a Arrhenius Model and Coffin-Manson Model to obtain parameters, and then using the formula with the parameters, the longevity and in so the reliability is proved.

Arrhenius Model: $Af = e\{ (1/k \times Ea (1/273+Tmax - 1/273+Ttest))\}$

Coffin-Manson Model: $Af = (\Delta Ttest/\Delta Tuse)m$

➤ APRO uses the A method to Estimate MTBF

MTBF is actually obtained by calculation which is just an estimation of future occurrences. The main reason to use the first method is that the data contains the analysis by all the parameters of components and actual parameters of voltage and electrical current of finished products, which is considered adequate and objective.

➤ Interpretation of MTBF Analysis

APRO estimates MTBF using a prediction methodology based on reliability data for the individual components in APRO products. The predicted MTBF based on Parts stress analysis Method of Telcordia Special Report SR-332, for components failure rates. Component data comes from several sources: device life tests, failure analysis of earlier equipment, device physics, and field returns.

The Telcordia model is based on the Telcordia document, Reliability Prediction Procedure for Electronic Equipment, Technical Reference SR-332. This standard basically modified the component models in MIL-HDBK-217 to better reflect the failure rates that AT&T Bell Lab equipment was experiencing in the field and was originally developed by AT&T Bell Lab as the Bellcore model.

This model supports different failure rate calculation methods in order to support the taking into account of stress, burn-in, laboratory, or field data. A Parts Count or Parts Stress analysis is included in Telcordia performance. Relex supports Telcordia Issues 1 and 2 and also Bellcore Issues 4, 5, and 6. Telcordia Issue 2, released in September 2006, are supported by Relex and Telcordia Issue 1, released in May 2001, is replaced with Relex. Refer to Telcordia Issue 2 Fields for information about the fields in Relex Reliability Studio specific to Telcordia Issue 2.

➤ Purpose of the analyses

The purpose of these analyses is to obtain early estimation of device reliability during engineering and customer validation stages. The prediction results will expose the reliability of whole assembly, viewed as a set of serially connected electronic components. Rating of the assembly electronic components will show the ratio between actual critical elements parameters and their specification limits. The purpose of component rating is to improve a product's inherent design reliability, increase its number of operating times, and to reduce warranty costs and to achieve a more robust design.

1.6.3. Definitions

| Term | Definition |
|-----------------------------------|---|
| Failure | The event, or inoperable state, in which any item or part of an item does not, or would not, perform as previously specified. |
| Failure rate | The total number of failures within an item population, divided by the total number of life units expended by that population, during a particular measurement interval under stated condition. |
| FIT | Failures In Time: the number of failures in 1 billion hours. |
| PPM | Part per million: the number of failures in 1 million hours. |
| Mean Time Between Failures (MTBF) | A basic measure of reliability for repairable items: The mean number of life units during which all parts of the item perform within their specified limits, during a particular measurement interval under stated conditions.. |
| GB | Ground, Fixed, Controlled: Nearly zero environmental stress with optimum engineering operation and maintenance. Typical applications are central office, environmentally controlled vaults, environmentally controlled remote shelters, and environmentally controlled customer premise area. |

| | |
|----|--|
| GF | Ground, Fixed, Uncontrolled: Some environmental stress with limited maintenance. Typical applications are manholes, poles, remote terminals, and customer premise areas subject to shock, vibration, temperature, or atmospheric variations. |
|----|--|

➤ **Software & Database**

Analysis Software & Analysis Method

Software Name : Relex Reliability Studio 2008

Software Version : Relex Studio 2008

➤ **Analysis Method**

The prediction method used was Telcordia SR-332, Issue 2,

Parts Count

Failure rate (λ) = 10^9 hours (FITs)

MTBF = $1/\lambda$

$$\lambda_{SSi} = \lambda_{Gi} \cdot TT_{Qi} \cdot TT_{Si} \cdot TT_{Ti}$$

Where λ_{Gi} : Generic steady-state failure rate for device i

TT_{Qi} : Quality factor for device i

TT_{Si} : Stress factor for device i

TT_{Ti} : Temperature factor for device i

➤ **Calculation Parameter**

Operation Temperature : 25°C

Environment : Ground Benign, Controlled

Operation Stress : 50% (Voltage, Current, Power)

Method : Method I, Case 3

Products are advertised with MTBF up to 1 million hours in the market. Take one million hours as an example, the product's estimated life is 114 years. However, the current rapid progress of technology, advancement of flash storage device's manufacturing process research and development, and the supply period of former flash IC manufacturing processes are crucial to the actual life expectancy of flash products. In short, the MTBF of flash storage is for reference only. Good customer service and technical support provided by manufacturers is the most significant issue regarding to the life-span of products.

Remark:

All the details of testing and data are for reference only and do not imply any products performance as a result. MTBF is only an estimated date and is depends on both hardware and software. User shall not assume that all the products have the same MTBF as APRO estimates.

2. Product Specifications

For all the following specifications, values are defined at ambient temperature and nominal supply voltage unless otherwise stated.

2.1. System Environmental Specifications

Table 1: Environmental Specification

| APRO SLC Industrial 2.5" SATA III SSD HERMES-HR Series | | Standard Grade SR2SRxxxG-JHCTC | Industrial Grade WR2SRxxxG-JHITI |
|---|----------------------------|---|-------------------------------------|
| Temperature | Operating: | 0°C ~ +70°C | -40°C ~ +85°C |
| | Non-operating: | -20°C ~ +80°C | -50°C ~ +95°C |
| Humidity | Operating & Non-operating: | 10% ~ 95% non-condensing | |
| Vibration | Frequency/Acceleration: | 70 Hz to 2000 Hz, 20G, 3 axes | |
| Shock | Operating & Non-operating: | 0.5ms, 1500 G, 3 axes | |
| Electrostatic Discharge (ESD) | Temperature: | 24°C | |
| | Relative Humidity: | 49% (RH) | |
| | +/-4KV: | Device functions are affected, but EUT will be back to its normal or operational state automatically. | |

2.2. System Power Requirements

Table 2: Power Requirement

| APRO SLC 2.5" SATA III SSD HERMES-HR Series | | |
|---|----------------|------------------|
| DC Input Voltage (VCC) | | 5V±5% |
| Maximum average value | Reading Mode : | 415.0 mA. (max.) |
| | Writing Mode : | 630.0 mA. (max.) |
| | Idle Mode : | 193.0 mA. (max.) |

2.3. System Performance

Table 3: System Performances

| | | | | | | | |
|-------------------------------|------------------------------|--|-------|-------|-------|-------|-------|
| Data Transfer Mode supporting | | Serial ATA Gen-III (6.0Gb/s = 768MB/s) | | | | | |
| 4KB Random access time | Read: | 0.11 ms. | | | | | |
| | Write: | 0.36 ms. | | | | | |
| Maximum Performance | Capacity | 8GB | 16GB | 32GB | 64GB | 128GB | 256GB |
| | Sequential Read (MB/s) | 400.0 | 490.0 | 530.8 | 500.4 | 512.7 | 512.7 |
| | Sequential Write(MB/s) | 120.0 | 210.0 | 236.9 | 349.2 | 354.6 | 354.6 |
| | 4KB Random Read IOPS (QD32) | 14.6K | 27.1K | 11.2K | 11.3K | 11.3K | 11.3K |
| | 4KB Random Write IOPS (QD32) | 10.4K | 21.4K | 5.9K | 5.5K | 5.5K | 5.5K |

Note:

1. The performance was measured using CrystalDiskMarkv5.0x64 with SATA 6Gbps host.
2. Samples were built using Toshiba SLC
3. Performance may differ according to flash configuration and platform.

2.4. System Reliability

Table 4: System Reliability

| | | |
|---------------------------------|---|----------|
| Wear-leveling Algorithms | Static wear-leveling algorithms | |
| Bad Block Management | Supportive | |
| ECC Technology | Hardware BCH ECC capable of correcting errors up to 66-bit/1KB (ECC). | |
| Erase counts | NAND SLC Flash Cell Level : 60K P/E Cycles | |
| TBW (Tera Bytes Written) | | |
| Capacity | 8GB | 432.0 |
| | 16GB | 864.0 |
| | 32GB | 1,728.0 |
| | 64GB | 3,456.0 |
| | 128GB | 6,912.0 |
| | 256GB | 13,824.0 |

Note:

- Samples were built using Toshiba SLC NAND flash.
- Test by sequential write.
- The endurance of SSD could be estimated based on user behavior, NAND endurance cycles, and write amplification factor.
It is not guaranteed by flash vendor.

2.5. Physical Specifications

Refer to Table 5 and see Figure 2 for APRO SLC Industrial 2.5" SATA III SSD HERMES-HR Series physical specifications and dimensions.

Table 5: Physical Specifications of APRO SLC Industrial 2.5" SATA III SSD-HERMES-HR Series

| | |
|-------------------|-------------------|
| Length: | 100.0 mm |
| Width: | 70.0 mm |
| Thickness: | 8.80 mm |
| Weight: | 75.0 g / 2.64 oz. |

2.6. Conformal coating

Conformal coating is a protective, dielectric coating designed to conform to the surface of an assembled printed circuit board. Commonly used conformal coatings include silicone, acrylic, urethane and epoxy. APRO applies only silicone on APRO storage products upon requested especially by customers. The type of silicone coating features good thermal shock resistance due to flexibility. It is also easy to apply and repair.

Conformal coating offers protection of circuitry from moisture, fungus, dust and corrosion caused by extreme environments. It also prevents damage from those Flash storages handling during construction, installation and use, and reduces mechanical stress on components and protects from thermal shock. The greatest advantage of conformal coating is to allow greater component density due to increased dielectric strength between conductors.

APRO use MIL-I-46058C silicon conformal coating

3. Interface Description

3.1. 2.5" SATA III SSD interface

APRO SLC Industrial 2.5" SATA III SSD HERMES-HR Series is equipped with 7 pins in the signal segment and 15 pins in the power segment.

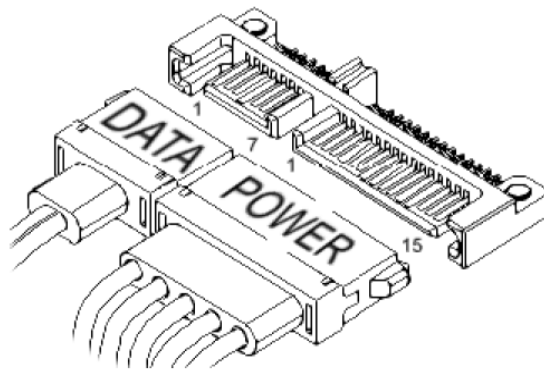

Figure 3: The connectors of Signal Segment and Power Segment

3.2. Pin Assignments

APRO SLC Industrial 2.5" SATA III SSD HERMES-HR Series operates with standard SATA pin-out.

The pin assignments are listed in below table 6.

| Name | Type | Description |
|------|------|----------------------------|
| S1 | GND | NA |
| S2 | A+ | Differential Signal Pair A |
| S3 | A- | |
| S4 | GND | NA |
| S5 | B- | Differential Signal Pair B |
| S6 | B+ | |
| S7 | GND | NA |

| Key and Spacing separate signal and power segments | | |
|--|---------|--|
| P1 | NC | NA |
| P2 | NC | NA |
| P3 | NC | NA |
| P4 | GND | NA |
| P5 | GND | NA |
| P6 | GND | NA |
| P7 | V5 | 5V Power, Pre-Charge |
| P8 | V5 | 5V Power |
| P9 | V5 | 5V Power |
| P10 | GND | NA |
| P11 | DAS/DSS | Device Activity Signal / Disable Staggered Spin up |
| P12 | GND | NA |
| P13 | NC | NA |
| P14 | NC | NA |
| P15 | NC | NA |

Table 6 - Pin Assignments

Appendix A: Limited Warranty

APRO warrants your SLC Industrial 2.5" SATA III SSD HERMES-HR Series against defects in material and workmanship for the life of the drive. The warranty is void in the case of misuse, accident, alteration, improper installation, misapplication or the result of unauthorized service or repair. The implied warranties of merchantability and fitness for a particular purpose, and all other warranties, expressed or implied, except as set forth in this warranty, shall not apply to the products delivered. In no event shall APRO be liable for any lost profits, lost savings or other incidental or consequential damages arising out of the use of, or inability to use, this product.

BEFORE RETURNING PRODUCT, A RETURN MATERIAL AUTHORIZATION (RMA) MUST BE OBTAINED FROM APRO.

Product shall be returned to APRO with shipping prepaid. If the product fails to conform based on customers' purchasing orders, APRO will reimburse customers for the transportation charges incurred.

WARRANTY PERIOD:

- **SLC STD. Grade 3 years / Within 60K Erasing Counts**
- **SLC IND. Grade 5 years / Within 60K Erasing Counts**

This document is for information use only and is **subject to change without prior notice**. APRO Co., Ltd. assumes no responsibility for any errors that may appear in this document, nor for incidental or consequential damages resulting from the furnishing, performance or use of this material. No part of this document may be reproduced, transmitted, transcribed, stored in a retrievable manner or translated into any language or computer language, in any form or by any means, electronic, mechanical, magnetic, optical, chemical, manual or otherwise, without the prior written consent of an officer of APRO Co., Ltd.

All parts of the APRO documentation are protected by copyright law and all rights are reserved.

APRO and the APRO logo are registered trademarks of APRO Co., Ltd.

Product names mentioned herein are for identification purposes only and may be trademarks and/or registered trademarks of their respective companies.

© 2018 APRO Corporation. All rights reserved