

# COMPLIANCE

## FCC STATEMENT

This device complies with part 15 of the FCC Rules. Operation is subject to the following two conditions: (1) This device may not cause harmful interference, and (2) this device must accept any interference received, including interference that may cause undesired operation.

This equipment has been tested and found to comply with the limits for a class B digital device, pursuant to part 15 of the FCC Rules. These limits are designed to provide reasonable protection against harmful interference in a residential installation. This equipment generates, uses and can radiate radio frequency energy and if not installed and used in accordance with the instructions, may cause harmful interference to radio communications. However, there is no guarantee that interference will not occur in a particular installation. If this equipment does cause harmful interference to radio or television reception, which can be determined by turning the equipment off and on, the user is encouraged to try to correct the interference by one or more of the following measures:

- Reorient or relocate the receiving antenna.
- Increase the separation between the equipment and receiver.
- Connect the equipment into an outlet on a circuit different from that to which the receiver is connected.
- Consult the dealer or an experienced radio/TV technician for help.

The user is cautioned that changes and modifications made to the equipment without the approval of manufacturer could void the user's authority to operate this equipment

In order to maintain compliance with FCC regulations, shielded cables must be used with this equipment. Operation with non-approved equipment or unshielded cables is likely to result in interference to radio and TV reception.

## CE CONFORMITY FOR EUROPEAN COUNTRIES

The device complies with the EMC Directive 2014/30/EU and Low Voltage directive 2014/35/EU.

## The following information is only for EU-member states:

The mark is in compliance with the Waste Electrical and Electronic Equipment Directive 2012/19/EU (WEEE).

The mark indicates the requirement NOT to dispose of the equipment including any spent or discarded batteries or accumulators as unsorted municipal waste, but use the return and collection systems available.

If the batteries, accumulators and button cells included with this equipment, display the chemical symbol Hg, Cd, or Pb, then it means that the battery has a heavy metal content of more than 0.0005% Mercury or more than, 0.002% Cadmium, or more than 0.004% Lead.

## FOR CANADA

CAN ICES-3 (B)/NMB-3(B)

## DECLARATION OF RoHS2 COMPLIANCE

This product has been designed and manufactured in compliance with Directive 2011/65/EU of the European Parliament and the Council on restriction of the use of certain hazardous substances in electrical and electronic equipment (RoHS2 Directive) and is deemed to comply with the maximum concentration values issued by the European Technical Adaptation Committee (TAC) as shown below:

Restricted Substance	Maximum Threshold Limit
Cadmium and its compounds	100 ppm (0.01 weight %)
Mercury and its compounds	1000 ppm (0.1 weight %)
Hexavalent chromium and its compounds	1000 ppm (0.1 weight %)
Lead and its compounds	1000 ppm (0.1 weight %)
Polybrominated biphenyls (PBB)	1000 ppm (0.1 weight %)
Polybrominated diphenyls (PBDE)	1000 ppm (0.1 weight %)
Bis(2-Ethylhexyl) phthalate (DEHP)	1000 ppm (0.1 weight %)
Benzyl butyl phthalate (BBP)	1000 ppm (0.1 weight %)
Dibutyl phthalate (DBP)	1000 ppm (0.1 weight %)
Diisobutyl phthalate (DIBP)	1000 ppm (0.1 weight %)

Certain components of products as stated above are exempted under the Annex III of the RoHS2 Directives. Lead as an alloy element in aluminium containing up to 0.4% lead by weight. Copper alloy containing up to 4% lead by weight. Lead in high melting temperature type solders (i.e. lead-based alloys containing 85% by weight or more lead). Electrical and electronic components containing lead in a glass or ceramic other than dielectric ceramic in capacitors, e.g. piezoelectric devices, or in a glass or ceramic matrix compound.

# SAFETY INSTRUCTIONS

## READ THESE INSTRUCTIONS. KEEP THESE INSTRUCTIONS. HEED ALL WARNINGS. FOLLOW ALL INSTRUCTIONS

- + Ensure that your computer system and all of its components are completely disconnected from any power source before you proceed to install the advoli™ TA4E Distance graphics card.
- + As with majority of electronic products that have exposed circuitry and that are not labeled as water proof - do not use the advoli™ TA4E Distance graphics card near water or liquids or with wet hands/body.
- + Ensure that the graphic card is not placed on surfaces or in an environment that inhibits air flow or blocks ventilation slots and fans. It is important that the graphic card has proper air flow to reduce temperature of GPU and other components and prevent over heating.
- + Avoid placing the graphics card or its computer in an environment or close to a source with significant heat, dust or humidity as it will destroy the advoli™ TA4E Distance graphics card.
- + Keep product on a safe, stable and secure surface before installing inside computer. Damage to this product will void warranty and will most likely result in it failing.
- + No item should rest on the graphics card or any of its components, such as power cord, fans or other cables. Ensure that none of the peripherals for your computer or computer itself is placed in such a way that the computer is damaged. A damaged computer will most likely damage its internal components such as the advoli™ TA4E Distance graphics card.
- + Ensure that you discharge any static electricity by touching a grounded surface before installing or touching the graphics card. Static electricity can damage components on the graphics card.
- + Ensure that you do not put pressure on or lift the advoli™ TA4E Distance graphics card by the fans. Do not touch the fans when they are operating.
- + All 4 channel advoli HDBaseT graphics cards come with Power over Ethernet (PoE) / Power over HDBaseT (PoH) enabled by default. If you use our products with other HDBaseT products from other manufacturers we do not guarantee that this function will work as some manufacturers implement PoE/PoH in non-standard ways. The PoE/PoH functionality is useful as you can power the advoli™ RA1 Performance or advoli™ RB1 Standard receivers from the graphics card. advoli™ is not responsible for any damage in any shape, way or form, caused to products or people when you use the PoE/PoH functionality with any other product than those listed here: advoli™ RA1 Performance and advoli™ RB1 Standard receivers.

## LEGAL

This document and its content is provided as is and only in connection with Advoli Limited (hereinafter referred to as "advoli™") products. advoli™ do not take responsibilities with respect to the accuracy or completeness of the contents herein and reserves the right to change or discontinue products, technical specifications, descriptions and documentation at any time without notice.

For product terms of sale and use, please visit [www.advoli.com/tosu](http://www.advoli.com/tosu)

advoli™'s products are not designed or authorised to be used for life critical and/or death situations and/or in any other situation where the failure of advoli™'s product could create an event where bodily injury, death and/or severe property and environmental damage may occur.

No license of intellectual property rights is given to any party at any time by this document, unless expressly written in a formal agreement between parties of such rights being granted. advoli™ assumes no liability whatsoever and makes no warranty relating to its products, except what is set forth in advoli™'s terms and conditions of sale.

Advoli, advoli™ and advoli logo are trademarks of Advoli Limited. Any other registered trademark or trademark of any other company, organisation or entity is exclusively used for informational purposes and advoli™ does not claim to own, be certified by, have licensed or be endorsed by any such entity or trademark.

This product is protected by copyright and product is protected by multiple published and pending patents in multiple territories and/or countries around the world. The use of this copyrighted and patented technology without the written authorisation of advoli™ is strictly prohibited. Reverse engineering or disassembly is strictly prohibited.

Although advoli™ has taken every precautions in preparing this document, Advoli Limited assumes no liability with respect to the operation of advoli™ software, hardware or any product or documentation described in this document. In no event shall advoli™ be liable for any incidental, special, punitive, consequential, or other damages whatsoever, including without limitations, interruption of service, loss or interruption of business, loss of expected profits, incidental or consequential damages in connection with the use of product, software and services referenced, regardless of whether provided by advoli™ or third party. The entire risk and consequences directly or indirectly arising from the use of this document, product, software and services referenced herein, remains with the user.

# advoli™

## ADVOLI TA4E DISTANCE QUICK START GUIDE

### EQUIPMENT LIST

- + 1 x USB 9-Pin Cable
- + 1 x USB 3.0 to 2.0 Adapter Card
- + 1 x advoli™ TA4E Distance graphics card, with MXM module and Fan Sink + Casing

### FEATURES

- + Drive 4 x FHD Displays at one time at a distance of up to 100 meters / 328 feet using shielded CAT cables
- + AMD Compact & Energy Friendly Embedded GPU E8860
- + Emulated universal IR emitter and decoder for each HDBaseT port. Physical bi-directional IR ports for IR pass-through
- + Emulated RS232 for all four HDBaseT ports
- + Emulated CEC Analyser for all four HDBaseT ports
- + Ethernet Switch on two ports and ethernet pass through on HDBaseT ports
- + Environmental Diagnostics
- + Passive and Active HDBaseT Tester for all four HDBaseT channels
- + EDID emulation, cloning and lock functionality in serial console
- + Power over HDBaseT / Ethernet (PoH / PoE) 48V 0.5A for each channel to power advoli HDBaseT receivers.

# BEFORE YOU INSTALL

## MUST ITEMS

+ Read the full installation guide before beginning, it can be found at: <http://www.advoli.com/ta4edistance/>

**Why?** You will make mistakes and you need to **read the warnings and safety related items!**

+ For troubleshooting & questions, please go to: <http://www.advoli.com/support/>

+ For drivers, please go to: <http://www.advoli.com/drivers/>

+ We highly recommend to start with a fresh installation of your operating system as drivers of other graphics cards are highly likely to interfere with driver of the TA4E Distance.

## CONNECTION ILLUSTRATION

1:

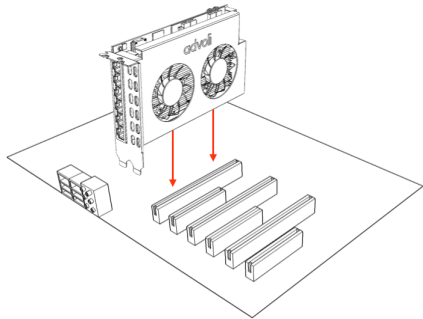

2:

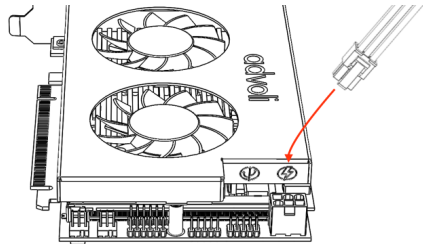

3:

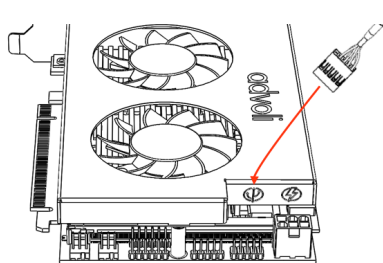

# HARDWARE INSTALLATION

**READ ALL SAFETY DIRECTIONS & WARNINGS IN THE COMPLETE INSTALLATION GUIDE LOCATED ON THE PRODUCT WEBSITE, BEFORE INSTALLING. ENSURE YOUR COMPUTER IS SWITCHED OFF AND ALL POWER CABLES ARE REMOVED FROM THE SYSTEM BEFORE PROCEEDING WITH INSTALLATION**

1. Remove any static electricity on your body before touching any electronic component.
2. Turn off and unplug the power cord to your computer and all of its peripherals. Wait for your system to cool down before proceeding.
3. Carefully insert the advoli™ TA4E Distance graphics card in the primary PCI express x16 slot. Ensure graphics card is firmly secured.
4. Connect one 6-pin PCI Express auxiliary power connector to the top right edge of the advoli™ TA4E Distance graphics card where there is a power connector.
5. Connect one 9-pin cable that comes with the advoli™ TA4E Distance graphics card to the to the top right edge of the advoli™ TA4E Distance graphics card and the other end of the cable to the motherboard USB 2.0 9-pin header. Use the converter board that comes along with the cable if your motherboard only has USB 3.0 header.
6. Close the computer casing/panel once you have completed the installation of the advoli™ TA4E Distance graphics card. You may now power up your computer.
7. Install driver from advoli website: [www.advoli.com/drivers/](http://www.advoli.com/drivers/) It is advised to use an already existing HDMI/VGA connector on the motherboard with a paired monitor to setup the driver for the graphics cards.
8. You will need to have CAT 5e/6/7/+ cables in at least one of the four RJ45 sockets with a HDBase™ certified display or HDBase™ certified receiver connected to a display in order to use the HDBase™ certified advoli™ TA4E Distance graphics card. You may use all four RJ45 sockets paired with their own display respectively. It is advised to use HDBase™ certified receivers to ensure compatibility. We highly recommend the advoli™ HDBaseT RA1 Performance receiver for guaranteed performance, please note that the RA1 does not have ethernet.
9. For further information on installing and using the product please go to the product page on advoli website for the complete installation guide.

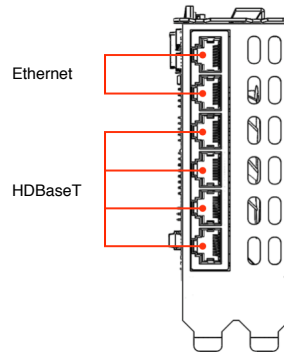

# SPECIFICATION

VIDEO	
# of HDBaseT Tx Channels	4 x RJ45 Connectors
HDCP 1.4 / 2.2	Compatible pass through
HDMI 1.4 / 2.0	Compatible pass through 300 MHz Pixel Clock Limitation
3D	Supported
Max Resolution	4K DCI 4096x2160 24Hz/25Hz/30Hz 4096x2160 30Hz @ chroma subsampling 4:4:4 8-bit
Max Resolution with all channels active	4 x FHD 60Hz
Color Space	YUV, RGB
Chroma Subsampling	4:4:4, 4:2:2, 4:2:0
Color Depth	8-bit, 10-bit, 12-bit
HDR	4K HDR10 @ 24Hz, 4:2:0 chroma subsampling, 10-bit
AUDIO	
Pass-Through	All formats supported by HDMI 1.4 and HDMI 2.0 All major digital audio formats, including: Dolby Digital, DTS, Dolby TrueHD, DTS HD-Master Audio, Dolby Pro Logic Iiz 7.1 & 9.1,
GRAPHICS / MXM	
Model	AMD™ Embedded E8860
MXM Type	A
Desktop Software by AMD™	AMD™ Eyefinity™
Driver provided by AMD™	Win 10 – 64 Bit / Win 8.1 – 64 Bit / Win 8.1 – 32 Bit / Win 8 – 64 Bit / Win 8 – 32 Bit / Win 7 – 64 Bit / Win 7 – 32 Bit / Linux x86_64 / Linux x86
Architecture	Graphics Core Next (GCN)™
Video Control	Direct GMA™
Compute Units	768 GFLOPS
Memory	2GB GDDR5. 128 bit wide
GPU Power	50W
Video Encode/Decode	UVD4 for H.264, VC-1, MPEG-2, MPEG-4 part 2 decode
Projector Edge Blend	Available through Third Party Software
Display Bezel Correction	AMD™ Eyefinity™
CONTROLS	
Diagnostics	HDBaseT™, Environmental & Electrical External IR Receiver Type A – 3 Pin Audio Jack Connector External IR Transmitter Type A – 3 Pin Audio Jack Connector
Infrared	Emulated IR IN/OUT – RAW Data External In/Out – 3 Pin Audio Jack Connector Emulated Serial Port IN/OUT (Virtual COM port) max baud rate: 115,200 bps
RS232	Pass through
CEC Compatible	Pass through
Ethernet	2 x RJ45 10/100 & Ethernet Pass Through on HDBaseT
EDID Management	Raw EDID pass through & EDID Serial Console Tools
PHYSICAL	
Fansink	Aluminium with 2 dual ball bearing fans
Dimensions	L: 167mm H: 106mm W: 39mm L: 6.6in H: 4.2in W: 1.5in
Dimensions of Packaging	L 350mm H: 70mm W: 195mm L: 13.8in H: 2.8in W: 7.7in
Weight of Product	356g +/- 10g OR 12.56oz +/- 0.35 oz
Weight of Packaging & Product	0.64 kg / 22.5 oz +/- 0.5 oz
Form Factor	Half-length, dual width Graphics Card
ENVIRONMENTAL	
Ambient Operating Temp	0°C to 40°C / 32°F to 104°F
Storage Temp	-20°C to 60°C / -4°F to 140°F
Humidity	20 to 90% non-condensing