

IDK-2115

15" XGA 1,200 cd/m² Ultra High Brightness Industrial Display Kit with LED B/L

NEW



Features

- 15" LCD supports 1024 x 768 pixels and wide operating temperature (-20 ~ 70° C)
- Ultra-high brightness of 1200 cd/m² with LED backlight
- High contrast ratio of 2500:1
- Wide view angle of 176°/176°
- Superior sunlight readability
- LVDS signal interface
- 5W resistive touch solution (optional)
- Anti-Reflection surface treatment (optional)
- Manually VR brightness control (optional)
- Auto-dimming solution with light sensor (optional)
- Optical bonding (optional)

Introduction

The Advantech IDK-2115 series comes with a 15" 1200 cd/m² industrial grade LCD display, and an LED driver board. The series is also available with flexible options for 5-wire touch screens and enhanced treatment such as anti-reflection surface treatment and optical bonding solution. IDK-2115 series supports 1200 cd/m² high brightness. Equipped with high level of brightness and wide operating temperature, IDK-2115 provides superior sunlight readability and is perfect for applications whether in semi-outdoor or outdoor environments.

Specifications

| | | |
|-------------------------|-------------------------|-------------------------------|
| LCD Panel | Size | 15", 4:3 |
| | Resolution | 1024 x 768 (XGA) |
| | Display mode | Normally Black (MVA) |
| | Viewing Angle (U/D/L/R) | 88°/88°/88°/88° |
| | Brightness | 1200 (cd/m ²) |
| | Contrast Ratio | 2500 : 1 |
| | Response Time (ms) | 23 ms |
| | Colors | 6bit (262K)/8bit (16.2M) |
| | Input Voltage / Current | 3.3 V / 0.8A |
| | Power Consumption | 18.36 W (W/ LED Driver Board) |
| | Signal Interface | 1 channel LVDS |
| | Weight | 1010 g(W/ LED Driver Board) |
| | Dimensions (W x H x D) | 326.5 x 253.5 x 9.1 mm |
| LED Driver Board | Efficiency | 90% |
| | Input Voltage / Current | 12V / 1.31A |
| | Dimensions (W x H x D) | 80 x 54.2 x 10 mm |
| Touch Screen (R series) | Touch Screen | 5-wire Resistive |
| | Transparency | 80± 3% |
| | Durability | 10 million times |
| Environment | Operating Temperature | -20 ~ 70° C |
| | Storage Temperature | -25 ~ 80° C |

LED Driver Board

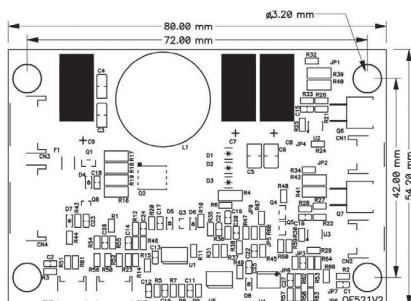

Touch Control Board

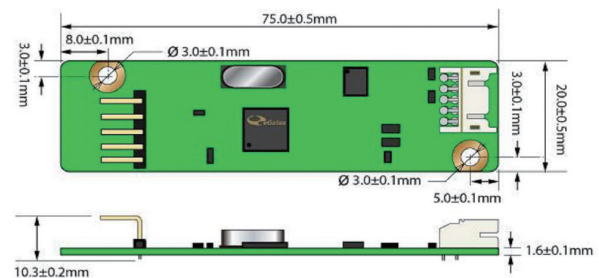

Dimensions

Unit: mm

IDK-2115N Series

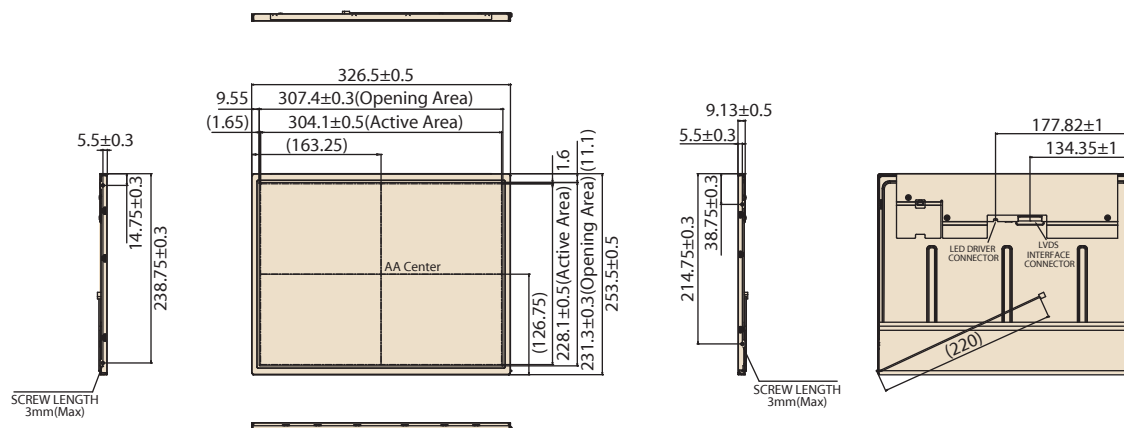

IDK-2115R Series

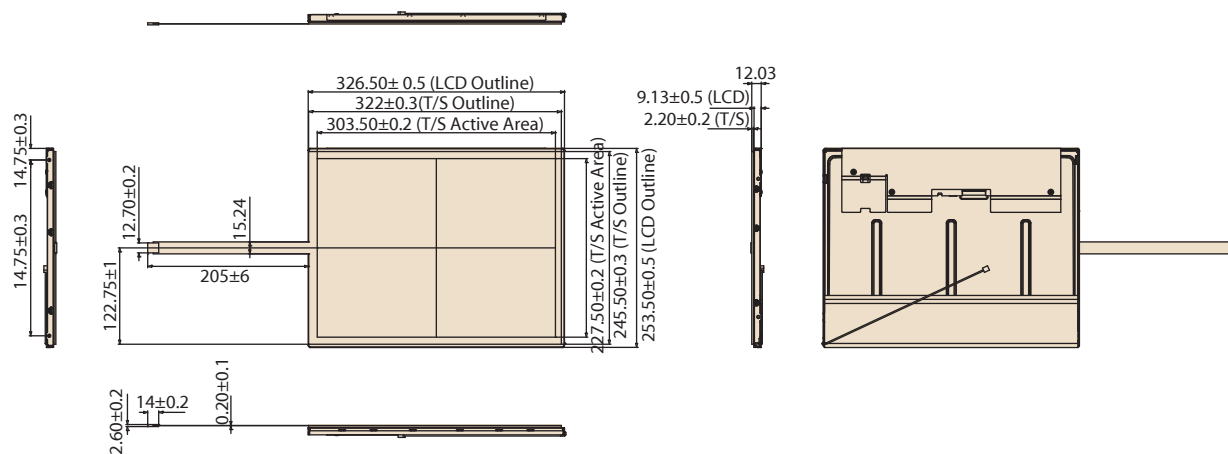

Ordering Information

| Part No. | Size | LCD Brightness (cd/m ²) | Interface | Touch screen | Touch Interface |
|------------------|------|-------------------------------------|-----------|------------------|-----------------|
| IDK-2115N-K2XGB2 | 15" | 1200 | LVDS | N/A | N/A |
| IDK-2115R-K2XGB2 | 15" | 1200 | LVDS | 5-wire Resistive | USB |

Packing List

| Part Number | Description |
|-------------------|--|
| 9680002141 | 1 x LED driver board |
| ETM-RES04C-EEH4EE | 1 x USB touch control board (IDK-2115R-K2XGB2) |
| 1700020324-01 | 1 x USB cable for Touch control board (IDK-2115R-K2XGB2) |

Note: Package contents are subject to change without prior notice

Optional Order

| SBC Part No. | LVDS cable P/N | Display interface | B/L cable P/N | Touch interface | Touch power input |
|--------------|----------------|---------------------------------|----------------|-----------------|-------------------|
| MIO-5270 | 96CB-L2040PCG4 | Single channel 18bit LVDS (XGA) | 96CB-E0605HAB1 | USB | 5V |
| PCM-9362 | 96CB-L2020PCG2 | Single channel 18bit LVDS (XGA) | 96CB-E0605HAB1 | USB | 5V |
| AIMB-270 | 96CB-L2040PCG4 | Single channel 18bit LVDS (XGA) | 96CB-E0605HAB1 | USB | 5V |

For more compatible embedded board solution, please visit our Build Your Display web page as below:
<http://www.advantech.com/buildyourdisplay>