



**Pentair**  
Technical Products

*Hoffman*<sup>®</sup>

# Open Frame Racks & Accessories

*Hoffman*<sup>®</sup>

**McLean**  
COOLING TECHNOLOGY

*Birtcher*<sup>®</sup>

**CALMARK**

*Schroff*<sup>®</sup>

## Application

- ▶ 2/4-Post Open Frame Racks combine the mounting security of a cabinet with the accessibility of a rack. No top cover, side panels and doors available.
- ▶ CableTek is a industry leading cable management system to open frame racks. With additional accessories the structured cabling of fibre and cooper wires is ensured.
- ▶ The 4 post open is an adjustable-depth racks supporting deeper, heavier network equipment and can be ganged with standard 2-post or other 4-post racks to expand existing systems.



# Overview Products

Item Number	Description (English)
EDR19FM45U	<a href="#">Open LAN Rack, 19 in x 45U</a>
E4DRS19FM45U	<a href="#">4 Post Rack, Sq. H, 19" x 45U</a>
DCHD2	<a href="#">Horiz Cable Mgr 2RU, Dbl Side</a>
DCHS1	<a href="#">Horiz Cable Mgr 1RU, Sgl Side</a>
DCHS2	<a href="#">Horiz Cable Mgr 2RU, Sgl Side</a>
EWFT	<a href="#">Waterfall top</a>
ECT19	<a href="#">Cord Trough</a>
P4SPOOL	<a href="#">Cable distribution spool (10)</a>
DV10D7	<a href="#">Vert Cbl Mgr,45RU,Dbl Side,Finger</a>
ES1224B	<a href="#">Screw Pkg (20) #12-24 Steel Black</a>
ES1224B250	<a href="#">Screw Pkg (250) #12-24 Steel Black</a>
EJ2DR	<a href="#">Joining Kit</a>
D19FVT69B	<a href="#">Tool-less Shelf 495 to 851</a>
D19FVT912B	<a href="#">Tool-less Shelf 792 to 1151</a>
EC3D7	<a href="#">Vert Cbl Mgr 3"x84" Dbl Side</a>



## 2 & 4 Post Racks



### Technical Details

- ▶ **Finish:** Smooth RAL 9005 black polyester powder paint finish
- ▶ Uprights on the tapped-hole model are made of lightweight extruded aluminum (6063-T6 alloy) and include RU markings on both front and back of uprights
- ▶ Uprights on the square-hole model are made from 12 gauge steel
- ▶ Top and bottom angles made of extruded aluminum
- ▶ **Standards:** UL 1863 Listed; File No. E230874 cUL Listed per CSA C22.2 No. 182.4; File No. E230874

## 2 & 4 Post Racks



- ▶ Shipped flat pack, easy to store and transport; low initial price
- ▶ Easy to install
- ▶ Used for heavier weight applications
- ▶ Equipment can be front or center mounted
- ▶ All racks capable of being ganged for expansion
- ▶ Common accessories between manufacturers as 19"
- ▶ Tapped & square hole patterns for 4 post rack

## 4 Post – Unique Feature

**Pentair  
Patented**



- ▶ Unique three piece telescoping front to back bracket.
- ▶ Adjustable from 450 mm to 1050 mm in depth

# Static Load

According to UL 1863

- ▶ 2 Post Open Frame – 453,6 kg
- ▶ 4 Post Open Frame – 1134 kg

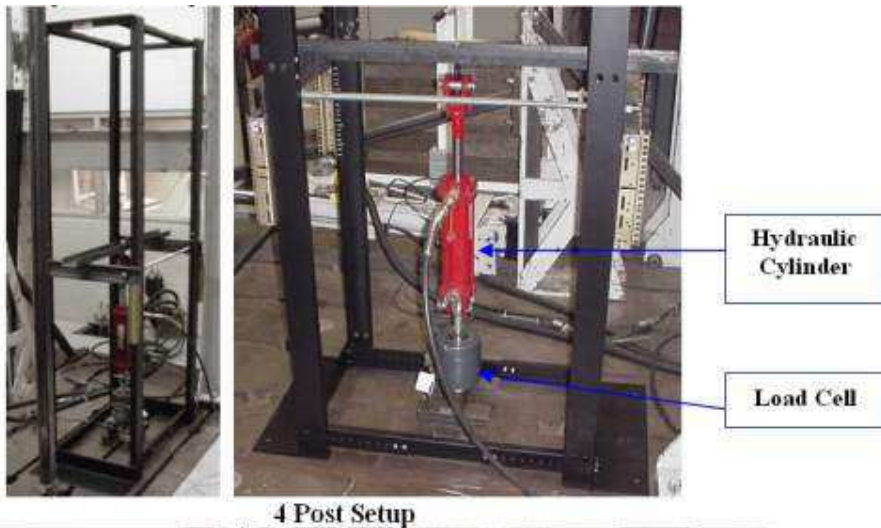

---

## Test Background

- ▶ 4 Post Open Frame Racks had shelves installed and loaded to 2,600 lbs (1080kg)
  - Each shelf had a load applied
  - Rack showed no signs of stress or imminent failure
- ▶ **Static Load Recommendations:**
  - Rack must be secured to the floor
    - Floor must be flat or the cabinet must be shimmed level
  - Load is across both sets of uprights
  - Point loads need further analysis
- ▶ **Maximum Static loading**
  - 4 Post Open Frame Racks are capable of Non UL 1863 Loads of 2,600 lbs



# Portfolio Overview – Open Frame Racks

## Accessories

- ▶ EWFT Waterfall Top
- ▶ ECT19 Cord Trough
- ▶ P4SPOOL Cable Distribution Spool(10)
- ▶ ES1224B Screws (20pcs) UNC 12-24 Black
- ▶ ES1224B250 Screws(250pcs) UNC 12-24 Black
- ▶ EJ2DR Side-by-side kit



## Additional Accessories Tool-less Shelf

- ▶ Easy to install, tool-less vented 19" shelf
- ▶ Slides open and provides a variable-sized, continuous surface for equipment
- ▶ Back of shelf has oval cutouts for power and data cables
- ▶ Made of steel with a 150 lb. (68 kg) static load rating
- ▶ Available with RAL9005 black or RAL 7035 grey polyester powder coat finish



- ▶ D19FVT69B      19.5in (495 mm) – 33.5 in (891 mm) depth
- ▶ D19FVT912B    31.2in (792 mm) – 45.3 in (1151 mm ) depth

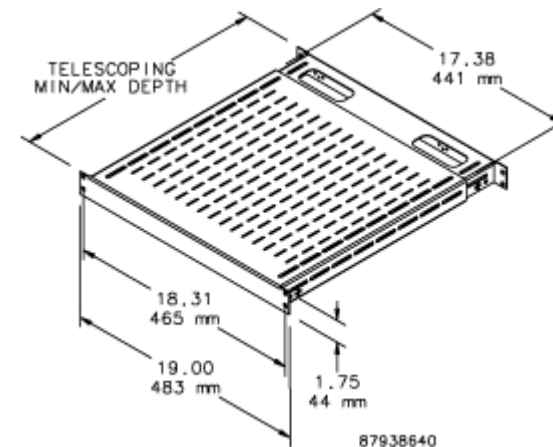

# Portfolio Overview– CableTek

## Vertical Cable Manager

- ▶ DV10D7      Vertical Cable Mgr 45U double sided 10in (254mm)
- ▶ EC6D7      Vertical Cable Manager 45U double sided 6in (152.4mm)
- ▶ EC3D7      Vertical Cable Manager 45U single sided 3.5in (89mm)

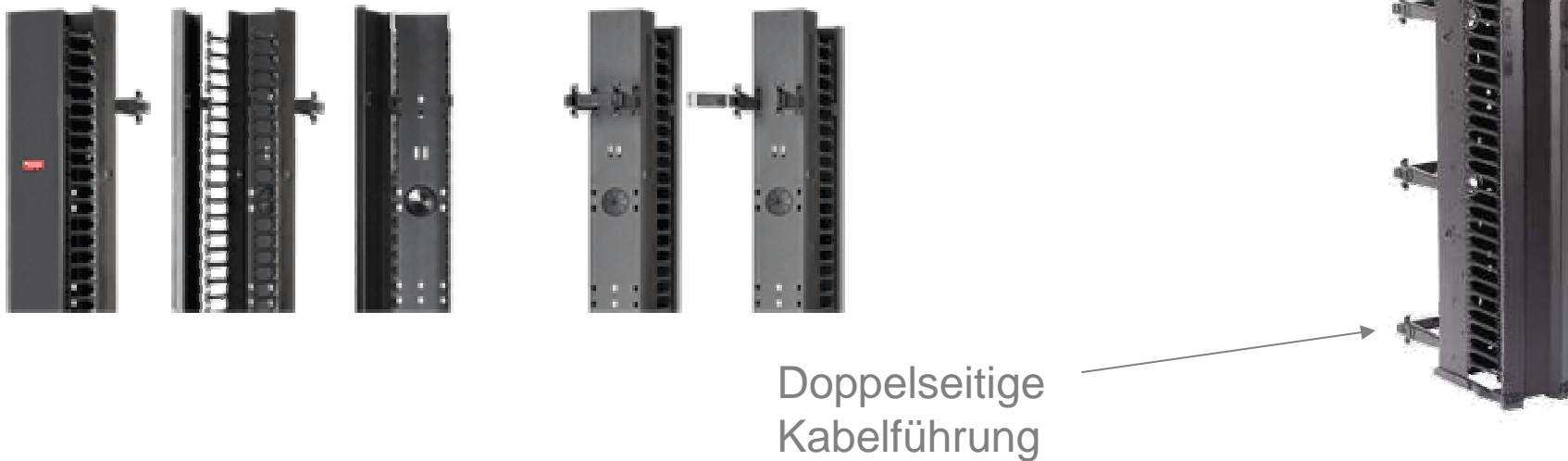

## Portfolio Overview – CableTek

- Easy to remove front door
  - Hinge left or right
  - Open **180°** to provide full access
  - Easy to remove when to provide maximum cable access
- Design
  - Arrow head easy cable insert design
    - Rapid cable assembly
    - High Capacity fill rate



## Portfolio Overview – CableTek

### Horizontal Cable Manager

- ▶ DCHD2            Horizontal Cable Mgr 2U, double sided
- ▶ DCHS1           Horizontal Cable Mgr 1U, single sided
- ▶ DCHS2           Horizontal Cable Mgr 2U, single sided



Double Sided



Single Sided

# CableTek Horizontal Manager

## Overview:

- ▶ Composite construction
  - Durable injected molded composite material
  - Low gloss black finish
  - Rigid design
- ▶ All edges radiuses
  - No tearing or gouging of cable jackets
  - Design
    - Arrow head easy cable insert design
      - Rapid cable assembly
      - High Capacity fill rate
- ▶ Aesthetics
  - Matching aesthetics for system look between Vertical and Horizontal cable mangers



## Transportdimensions

Item number	Hight in mm	Width in mm	Depth in mm	Weight in kg
-------------	-------------	-------------	-------------	--------------

EDR19FM45U	107,95	65,1	2.146,30	13,61
E4DRS19FM45U	107,95	203,2	2.184,40	38,56

DV10D7	355,6	441,45	2203,45	19,96
EC6D7	152,00	457	2134	23,13
EC3D7	89,00	457	2134	20,87

## Summary - Why open frame racks...

- ▶ Low cost to use
- ▶ Easy to assemble
- ▶ Easy to store and transport
- ▶ Easy to cable
  
- ▶ High cable capacity
- ▶ Systematic design
  - Horizontal and Vertical are designed to work together
  - Reduced need for sharp bends – No keep-out areas!
  
- ▶ Great aesthetics
  - Covers on Vertical and Horizontal are similar



### Hoffman Open Frame Racks

Versatile solution for mounting network equipment, facilitates fast cable installation and organization.



Cables are protected from cuts, abrasions, and tears to their sleeving

Adjustable from 450 mm to 1050 mm in depth

**Your advantages**

- Low cost of use; shipped flat pack
- easy to store and transport
- easy to assemble
- easy to cable

High cable capacity adapts to current and future cable sizes, common accessories as 19" standard.

[pentairtechnicalproducts.com](http://pentairtechnicalproducts.com) [www.schroff.biz](http://www.schroff.biz)